

multiFLEX Technical Manual



Contents: M714_Tech Manual

Safety

1. Installation-Commissioning	3.
1.1 Cabling – Wiring	
1.2 LAN Communications	
1.3 Modem Communications	
1.4 Water Meters – Flowswitches – Contact Sets	
2. Control Configuration	11.
2.1 Methods	
2.2 Control Equations	
2.3 Interlocks	
2.4 Blocking Relays	
2.5 Control Method	
2.6 Special Controls	
2.6.1 Bleed & Feed	
2.6.2 Bleed then Feed	
2.6.3 Percentage Time	
2.6.4 Prebleed – Lockout	
2.6.5 Captured Sample – Boiler Controls	
2.6.6 Time Modulation	
2.7.7 Timed Cycling	
2.7.8 Holding Time	
2.7 Timed Events	
2.8 Variable Cycles	
2.9 Feed Verification	
3. Sensors	25.
3.1 Compensation	
3.2 Calibration	
4. System Configuration	28.
4.1 Power/Relay and I/O Modules	
4.2 Installing Sensor & 4-20mA Drivers	
4.3 System Settings	
4.4 Module Testpoints	
Appendix	34.
A. Resource Index	

Safety



CAUTION: The operator of this instrument is advised that if the equipment is used in a manner not specified in this manual, the protection provided by the equipment may be impaired.



Electrical Shock Hazard

Opening the controller enclosure with the controller plugged in, exposes the user to AC line voltages on the lower of the two controller circuit boards.



USER WARNING : CAUTION

Water Treatment Controllers operate steam and water valves and may pump hazardous, corrosive and toxic chemicals. Opening the controller enclosure exposes user to the risk of electrical shock at power line voltages.

Understand fully the implications of the control setpoints, interlocks and alarms that you select. Harm to personnel and damage to equipment may result from mis-application.

Unplug or turn OFF the AC power to the controller if you have any concerns regarding safety or incorrect controller operation and notify supervisory staff.

INDIVIDUAL CONTROLLERS

Controllers are supplied in many different configurations.

The **HELP** section in the M714_User manual contains the information for terminating the sensors supplied with each controller.

The **HELP** section in the M714_User manual depicts the installation plumbing header showing the sensor set supplied with each controller.

1. Installation-Commissioning

1.1 Cabling – Wiring

Controllers consist two circuit boards, an upper sensor module and a lower power module. The top circuit board is either an **M7**, 7 Analog I/O & 6 digital Input or an **M14**, 14 Analog input & 12 digital input module. Both **M7** & **M14** include a LCD display and microcontroller module. The lower circuit board is either a **PR5**, 5 Power Relay or **PR10**, 10 Power Relay module. Both **PR5** & **PR10** include an alarm relay.

Controller Orientation

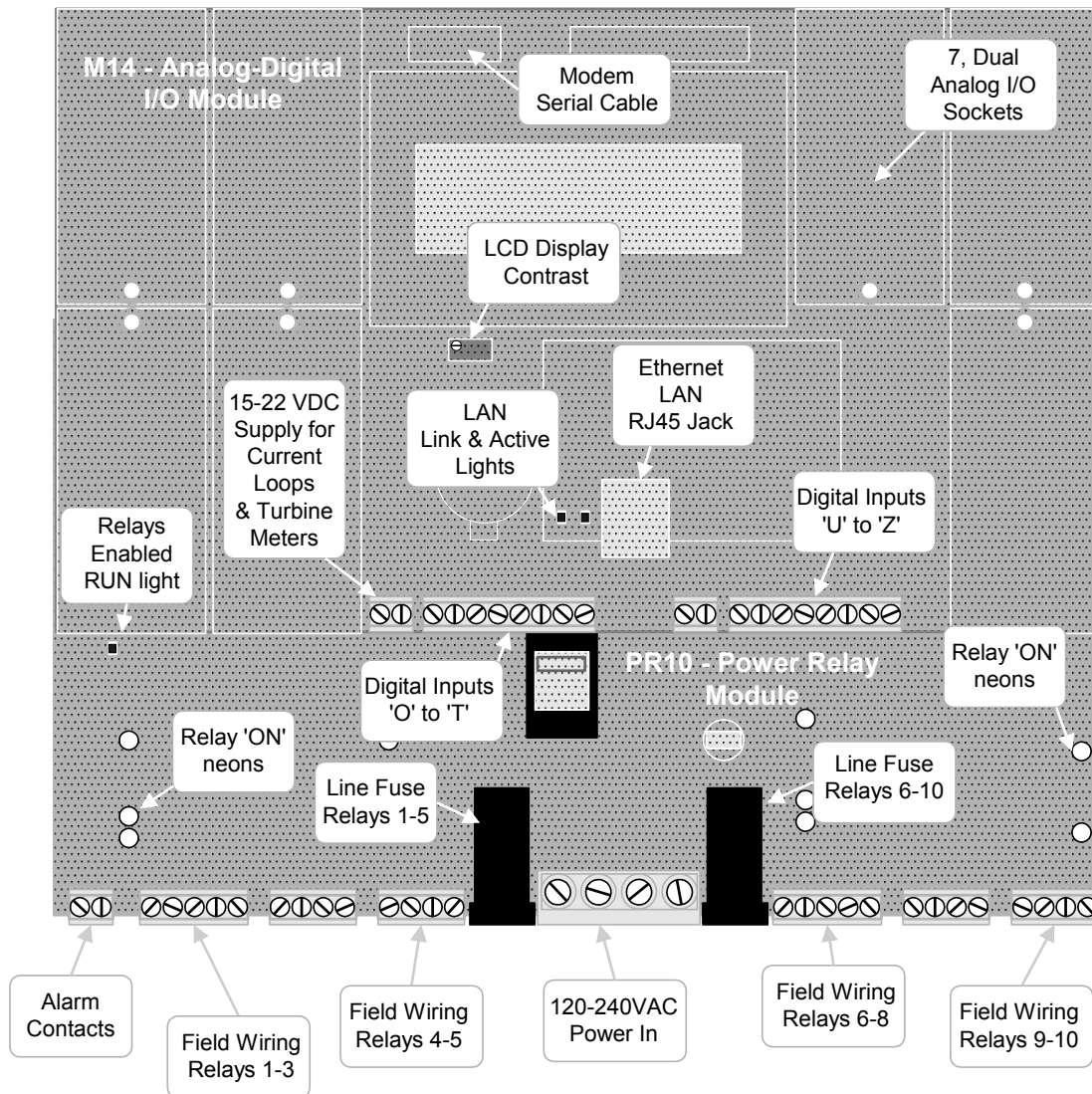

120 VAC Controllers – Plug Box(es)

Controllers with pump controls are supplied one or more prewired 120VAC plug boxes. Wired as shown in the following graphic. Individual plugs are labeled with the pump type; Inhibitor, Acid Pump, Oxidant, Bleed etc.

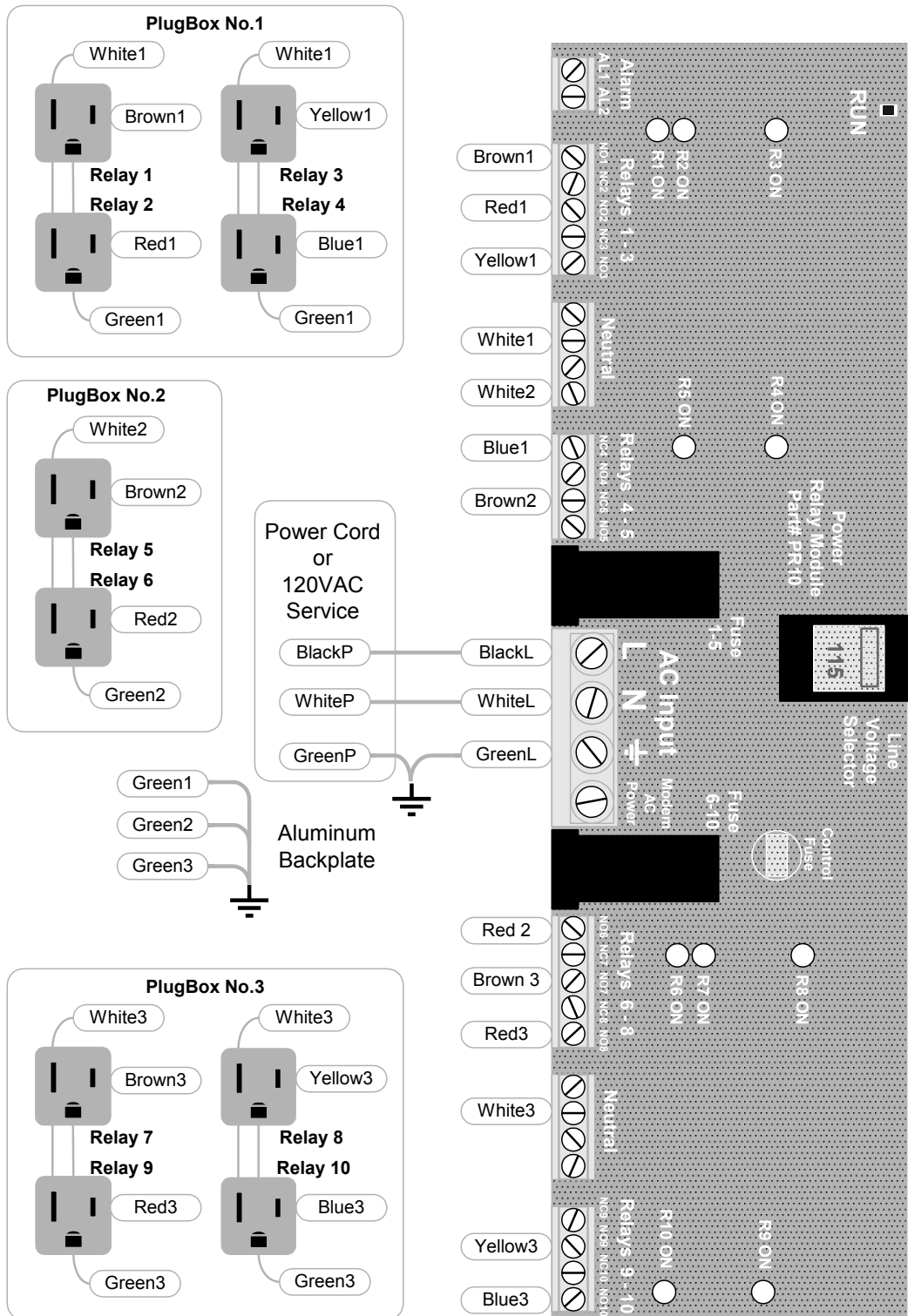

AC Power Wiring

Connect AC power ground to the aluminum backplate grounding screws located center, bottom. Relay **Neutral** terminal blocks are commoned to the AC power input terminal **N**. When a relay is ON, the **NO** terminal is at AC input **L** voltage and the neon light is ON. When a relay is OFF, the **NC** terminal is at AC input **L** voltage and the **NO** terminal is disconnected.

Analog Sensor Wiring

Each analog sensor, Conductivity, pH, ORP, Corrosion Rate, is identified by a letter A..N. Assigning a fixed letter to each sensor, allows the user to modify the sensor name while maintaining the physical location of the sensor driver and field wiring terminals. The user manual HELP section includes wiring information specific to the controller part number.



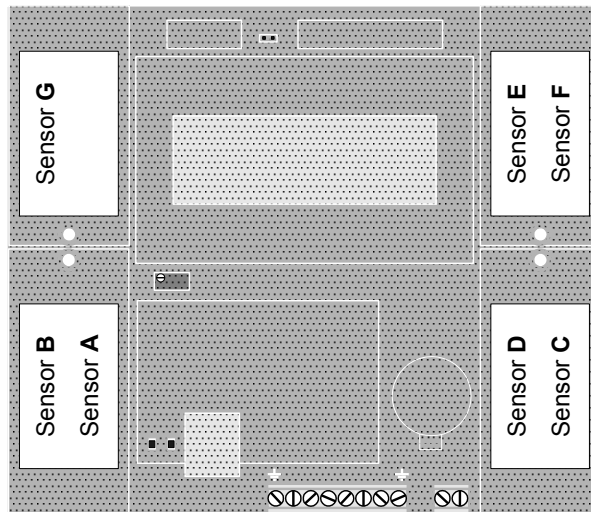

**M7 Module
Sensor Locations**

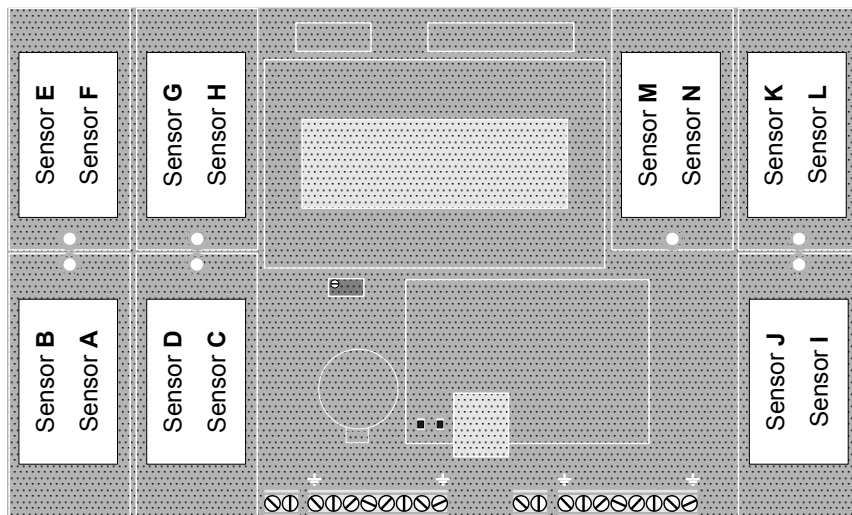

**M14 Module
Sensor Locations**



Analog Sensor Wiring

Sensor Type	Driver Type	Sensor 1 wiring	Sensor 2 Wiring
Conductivity & Temperature	CT	Red to S+ Black to S- White to T+ Green to T-	No sensor 2
Boiler – Condensate Conductivity	B	Black to S1 White to S1 Not polarized	Black to S2 White to S2 Not polarized
PH, ORP	OP	Coax Center to 1+ Shield to 1- Solution ground to 	Coax Center to 2+ Shield to 2- Solution ground to 
Corrosion Rate	CR	Red to S1 Black to S1 Not polarized	Red to S2 Black to S2 Not polarized
4-20mA inputs	CI	Loop + to 1+ Loop – to 	Loop + to 2+ Loop – to 
4-20mA outputs Auto polarity correction	IO	+ Out to 1+ - Out to 1-	+ Out to 2+ - Out to 2-

Wiring Rules

Analog sensors, contact sets, water meters and flowswitches may be cabled in a common conduit without causing operational problems.

Do not mix AC Line, 120VAC & 240VAC wiring with any sensor or communications cable in a common conduit.

Grounded, metallic conduit is preferred in areas where variable frequency drives operate.

Sensor cables, with the exception of pH sensors, may be extended in paired AWG22, 0.25mm² cable. Ensure that cabling splices are accessible in conduit fittings or junction boxes.

Verify that the shields on contact head water meters are also spliced when meter cables are extended.

1.2 LAN Communications

Controllers not connected to a network may be browsed using a crossover cable and a notebook's or local PC's browser

Refer to Application note AN_T004 for detail on notebook browser set-up.

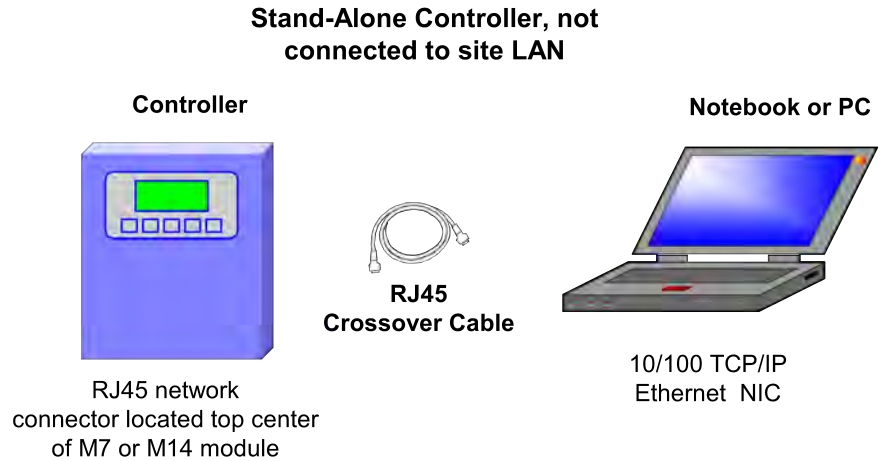

Controllers use a static IP address to communicate using TCP/IP 10 base T. Site IT provides LAN IP addresses and they may also wish to modify the ports used for HTML (default 80) and Telnet (default 23) . They may also require the controller MAC. Key ENTER @ System and DOWN to 'LAN Setup' to view & modify IP, Netmask & Gateway. MAC, HTML & Telnet ports are view only. Ports can be modified using a browser connection.

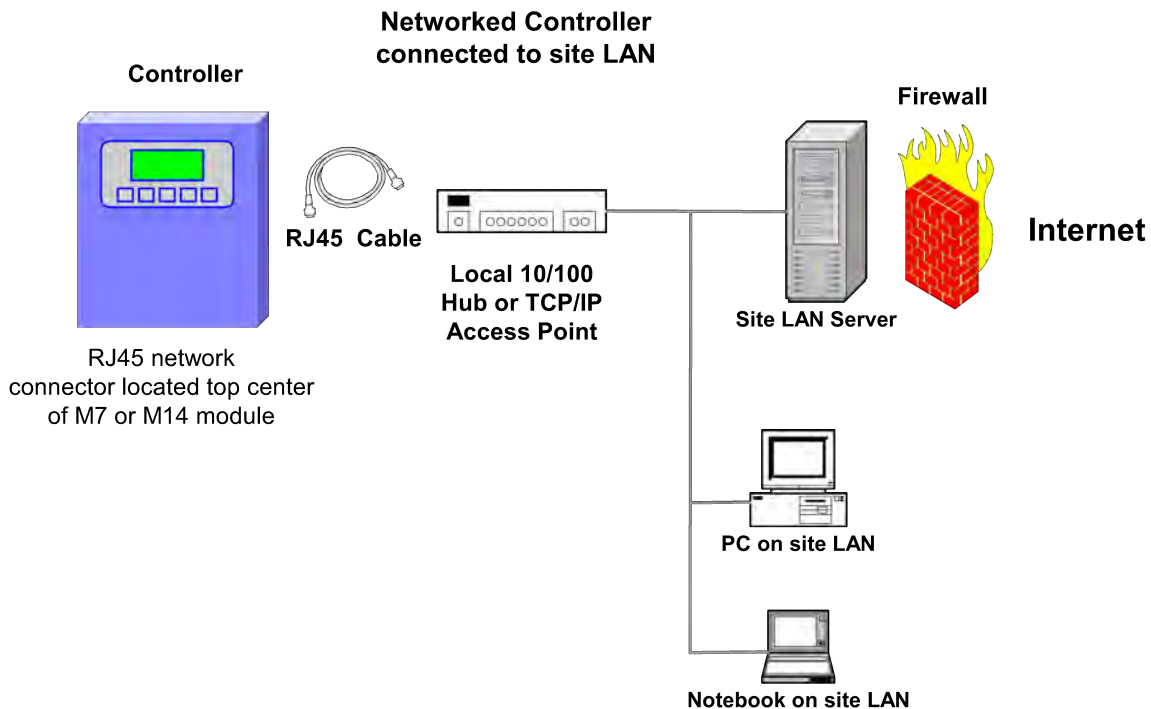

CAUTION: Exercise caution in making the controller Internet accessible. At a minimum, modify the factory default passwords for Admin and Users 1-7, before making a controller Internet accessible.

1.3 Modem Communications

1.3.1 Installation

Terminate the site telephone service in an RJ11 jack and plug it into the LINE modem jack.

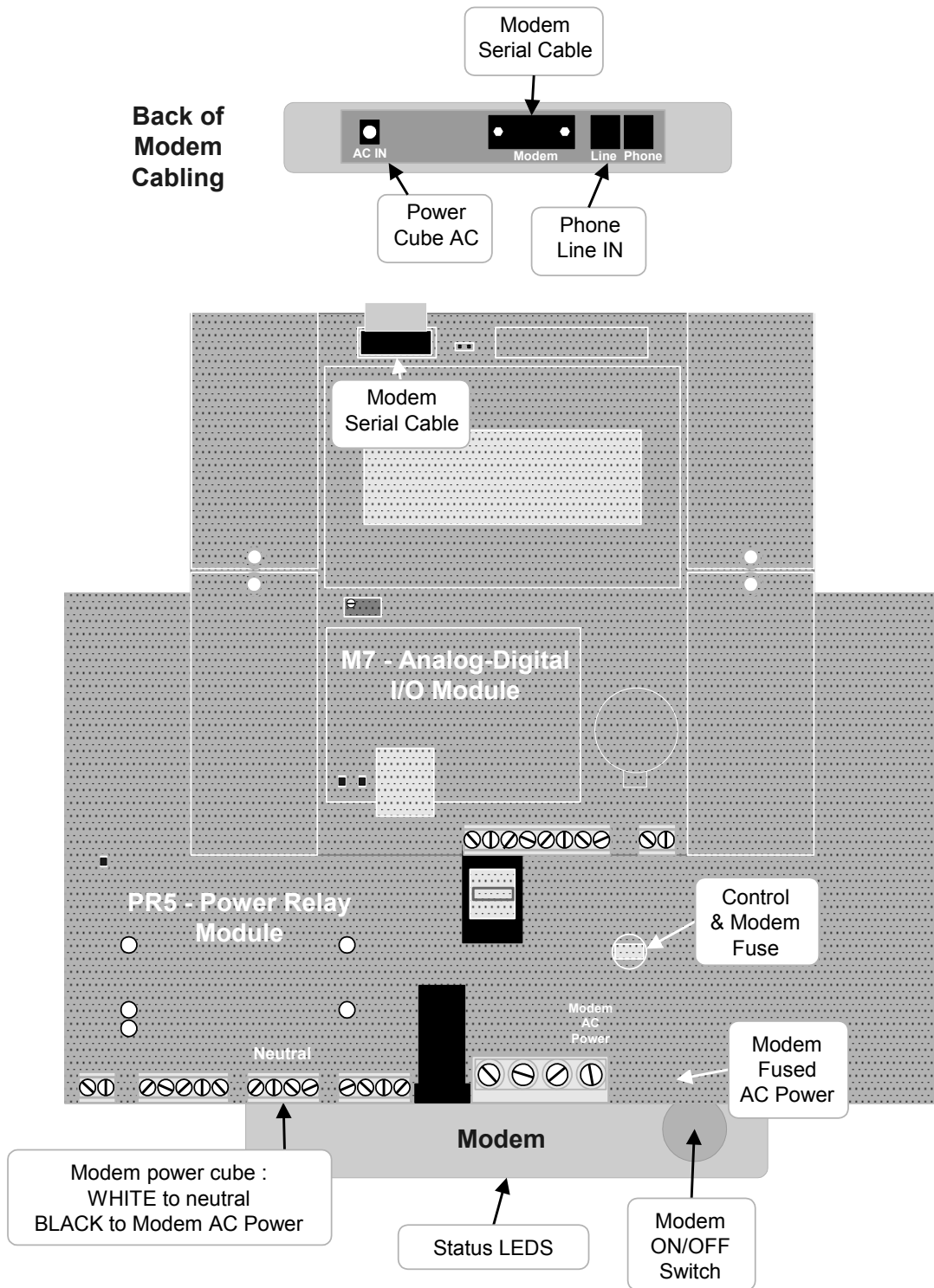

1.3.2 Modem Test

Controller Power Up:

Modem Status LEDs: ON red **MR,HS,TR,AA** & green **PWR**
OFF red **CD,OH,SD,RD**
Press modem power switch if no status LEDs ON

Browser: Select Communicate/Diagnostic; displays **OK**, verifying modem power ON & controller-to-modem serial connection operational.

Dialing in to a Controller Modem

Dial in to a controller requires an application like Trackster, which will make the telephone connection and then switch to Telnet for controller command and control.

If you manually dial a controller, it will pick up, time out and hang up because it cannot establish a modem-to-modem connection.

Browser Dial-Out Test Sequence

1. Select Communicate/Modem Setup and verify that a phone number exists in one of the four dial out slots. If no phone numbers exist, select Modify No.1, add Phone# & Submit. If you wish to test Page out, check Pager before Submit. Entering your cell phone# and selecting Pager is a simple test that verifies the site telephone service.
2. If you selected Pager, you now have the option to change the pager message (max 4 numbers) and modify the Pager Delay (max 250 seconds). Pager delay in seconds occurs after the number has been dialed and before the pager message is sent.
3. Start the modem test by selecting Communicate/Diagnostic & set Force Dial-Out to YES, select one of the four phone numbers then submit.
4. Key Refresh frequently if you wish to follow the test sequence. If for example you do not have a phone line connected to the modem & Pager has been selected, you'll view 'Testing', 'Pager Dial-out' and 'NO DIALTONE' in sequence.
5. If Pager is selected, the controller modem will dial the target phone#, wait the pager delay, send the pager message & hang-up.
6. If Pager is not selected, the controller modem dials out, expecting to connect to another modem at 19200. After connecting, the controller will send Controller Serial#, System Name, Location Name, Date, Time, Active Alarms one per line and then hang-up.
7. Each alarm line is comprised of an I/O Letter or Number, Name, Alarm type, Date, Time alarm tripped. Note that I/O points with 'dial-out on alarm' checked will dial-out every 60 minutes until cleared.
8. Delays of several minutes occur between sequential modem tests to allow for recovery from fault conditions; no carrier, loss of carrier detect...

1.4 Water Meters – Flowswitches – Contact Sets

Water meters, flowswitches and contact sets are connected between input terminal 'O' through 'Z' and a ground terminal. 5VDC limited by 10K puts 1/2mA through a closed contact set.

Hall effect Turbines and Paddlewheel water meters are powered by the 15-22VDC controller supply, thermally fused at 100mA.

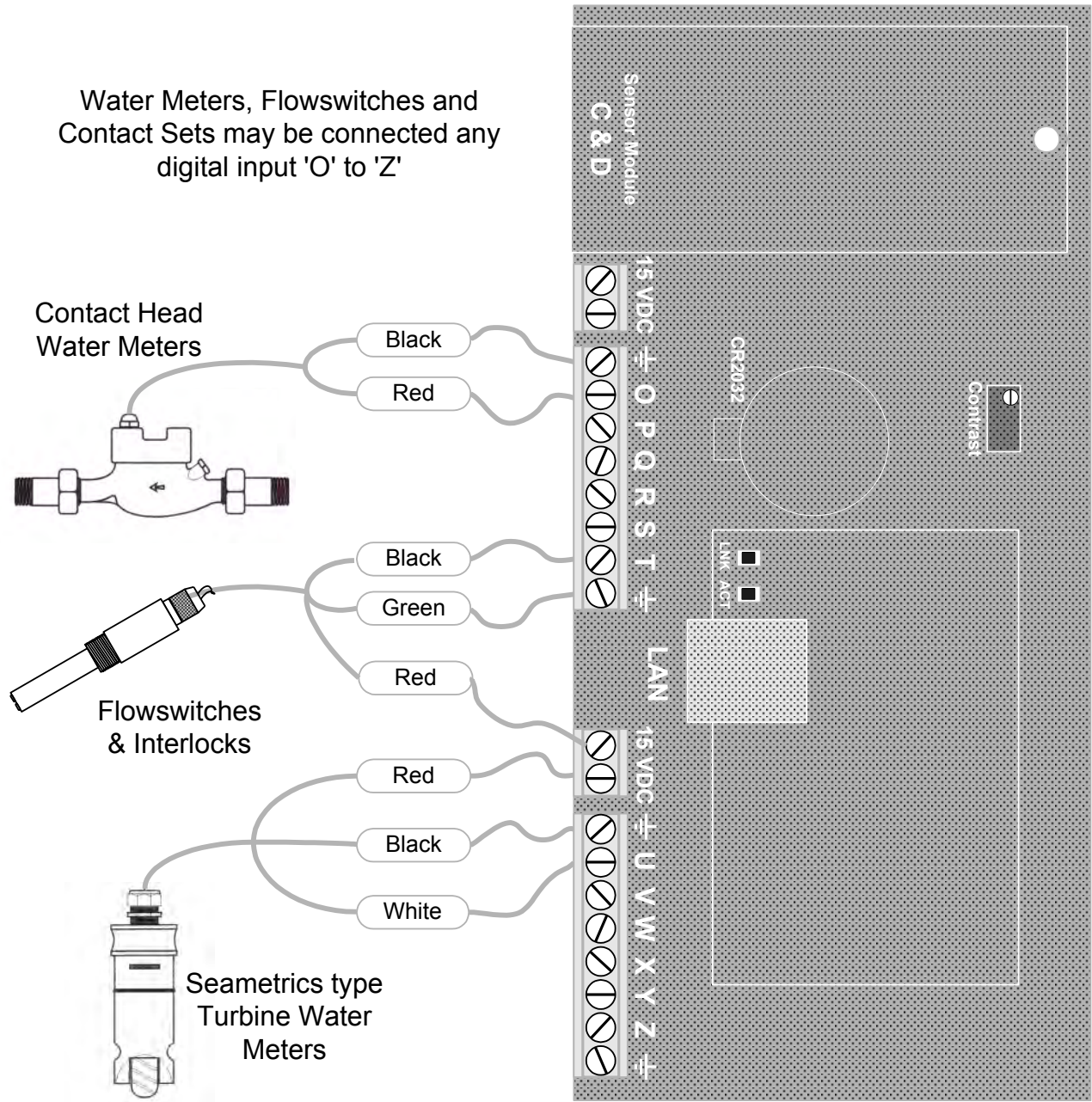

Connect cabling shields at the controller ends of the cable only, to any ground terminal either on the M7 or M14 module or on the aluminum backplate, bottom, center

2. Control Configuration

2.1 Methods

2.1.1 ON/OFF: RELAYS

Relay Outputs 1..10 without a control equation are OFF unless turned ON by a timed event, priming, bleed and feed, bleed then feed, percentage time or pre-bleed.

Sensor Control:

ON-OFF setpoint control by sensors A..N.

Control equations combine up to four sensor A..N.

Modified by 2.5 Control Method.

Volume Control:

Measure setpoint Volume then turn ON for setpoint Seconds.

Measure setpoint Volume 'O' then turn ON for setpoint Volume 'P'

Control equations combine up to four meters O..Z.

Status Control:

Turn ON setpoint seconds after contact set closes

Timed Controls:

Biocide Timing turn ON for user set period at user set Day & Time

Prebleed and Lockout on each Biocide timed event.

Bleed & Feed and Bleed then Feed based on bleed ON time.

Percentage ON time in every 5 minutes.

Detailed in 2.6 Special Controls.

2.1.2 PROPORTIONAL: 4-20 mA OUTPUTS

4-20mA Outputs C1..C8 without a control equation, in AUTO mode, are 4mA.

Sensor Control:

Analog sensor A..N, using the sensor value to control current level.

Relay Control:

Relay 1..10 using the value of the relay control equation to control current level.

Auto / Manual:

Switch between user set Manual % output and automatic control by Sensor or Relay value.

2.1.3 USEABLE, NON-EXISTANT I/O

Analog and Digital inputs and Relays that do not physically exist can be used for logging and control or as placeholders for blocking or as 4-20mA controls.

Examples:

Input 'M' in an M7 controller is used to log the results of a manual inhibitor ppm test.

Relay 8 in a PR5 controller is controlled by a 'C'-'D' temperature difference and the difference is used to control a 4-20mA output.

Water 'V' in an M7 controller is used to log the volume measured as GPM on analog input 'E'.

Input 'E' compensation is set to Rate-to-Volume', targeting input 'V'.

The resulting volume on 'V' is used to control relay 1 Inhibitor pump feed.

2.2 Control Equations

There are three types of sensors used for control, Analog Sensors A..N, Watermeters O..Z and Contact Sets O..Z. Sensor types cannot be combined in a Control Equation.

The first Input letter of the Control Equation is used to provide the Output units and resolution, grouping within the Browser view and LCD Display sequencing.

The controller blocks illegal control equations.

Control equations are verified on power up and Load from Flash.

Illegal control equations are removed.

Sensors used in control equations cannot be disabled.

Analog Sensors A..N:

Operators: + Sum, - Difference, / Division, *Multiply

Control Equation limited to four Inputs and three Operators.

The first letter of a control equation must be a letter A..N.

All sensors used in a control equation must be enabled.

The relay ON/OFF state on setpoints is controlled by 2.5 Control Method

Examples: E/F A+B/C*D G-N

Watermeter Sensors O..Z:

Operators: + Sum, - Difference, : Sequence

Sum & Difference control equations limited to four meters.

The first letter of a control equation must be a letter, water meter O..Z.

All water meters used in a control equation must be enabled.

Volume – ON Time Example:

Measure Water Meter Volume 200. Then Turn ON for 15 seconds.

Turn ON times accumulate & are displayed as Time Owed

Sequence Example:

O:P, measures a volume on O and the turns ON until the turn OFF volume is measured on P.

Sequence can be used for Water Meter Cycle Control and for volumetric chemical feeds:

Measure 100 Gallons, Feed 10mL.

Contact Sets O..Z:

Limited to one letter O..Z

Turn ON setpoint seconds after the contact set closes.

Turn OFF setpoint ignored.

Example:

Control equation = T. Turn ON setpoint = 30.

Relay turns ON 30 seconds after contact set 'T' displays 'ON' and stays ON until contact set T displays 'OFF'.

4-20 mA Output Controls:

Control equation may be one of an analog sensor A..N

OR

A Relay number 1..10. If a Relay number is used then the current value of the relay control equation is used to control the current level.

$$\text{Current Output in mA} = 4\text{mA} + 16\text{mA} \times (\text{Sensor Value} - 4\text{mA Value}) / (\text{Span})$$

Example:

Current Output C2 is controlled by pH sensor connected to input 'E'.

Tower pH 'E' = 7.91 pH

C1 is set to AUTO with 4mA = 5 pH and 20mA = 10.

C1 output current is 13.3mA $[4\text{mA} + 16\text{mA} \times (7.91 - 5) / (10 - 5)]$

2.3 Interlocks

When an Interlock contact set OPENS, the interlocked relay turns OFF

When an Interlock contact set OPENS, the interlocked 4-20mA output is 4mA

An open interlock contact set displays OFF. A closed interlock contact set displays ON.

Interlocks may be used with all three types of controls; analog sensors A..N, water meters O..Z and contact sets O..Z.

Note: 4-20mA outputs are limited to a single interlock O..Z,
ANDing & Oring interlocks does not apply to 4-20mA outputs.
Contact sets used in Interlocks cannot be disabled.

Example: Relay 2 controls a bleed solenoid. It's interlocked with contact set T.

Contact set 'T' would typically be a flowswitch.

When contact set 'T' opens & displays OFF, Relay 2 will turn OFF or will not turn ON.

The state on Relay 2 will be 'Interlocked T' when T is OFF.

'OR'ing contact sets:

If any one of the OR'ed contact sets is ON, the relay can turn ON.

Up to four contact sets may be 'OR'ed

The forward slash, '/' separates 'OR'ed contact sets

Example: Boiler Steam Line Treatment pump is interlocked with contact sets T/X/Y

The pump can operate whenever any one of T, X or Y is ON.

Typically T, X & Y are ON whenever boilers 1, 2 or 3 are ON.

'AND'ing contact sets:

All of the AND'ed contact sets must be ON, before the relay can turn ON.

Up to four contact sets may be 'AND'ed

The plus sign, '+' separates 'AND'ed contact sets

Example: A pH control operates when both Y+Z contact sets are ON

Where Y & Z are ON when both the transfer pump and the tank full contact sets are closed.

2.4 Blocking Relays

When a blocking relay turns ON; it turns OFF, blocks, the relay with that relay number in it's blocking field.

Example: Relay 1 feeds an inhibitor and has Relay 3 set in its Blocking field.

Relay 3 feed oxidant and has 'none' set in its Blocking field.

Whenever Relay 3 turns ON, Relay 1 turns OFF.

More than one blocking relay:

Up to four blocking relays may be set in any relay's blocking field as 2+4+8+9 where 2,4,8 & 9 are enabled relays.

The '+' sign separates more than one blocking relay

The controller prevents a relay from blocking itself.

2.5 Control Method

Sets the deadband response of an ON/OFF relay control

Applies only to relays controlled by sensors A..N

Method	Function	Examples
Rising Setpoint	ON: Sensor > Turn ON Setpoint OFF: Sensor < Turn OFF Setpoint	Tower Bleed Boiler Blowdown Condensate Bypass Acid Feed
Falling Setpoint	ON: Sensor < Turn ON Setpoint OFF: Sensor > Turn OFF Setpoint	Oxidant Feed Caustic Feed
Between Setpoints	ON: Sensor < Turn ON Setpoint & Sensor > Turn OFF Setpoint OFF: Sensor > Turn ON Setpoint Sensor < Turn OFF Setpoint	Blocking Controls Level Controls
Event Rising	Rising Setpoint Operates only during Timed Events	Acid wash – flush Cleaning controls
Event Falling	Falling Setpoint Operates only during Timed Events	Oxidant slug feeds
Event Between	Between Setpoints Operates only during Timed Events	Blocking – sequencing controls

2.6 Special Controls

2.6.1 Bleed & Feed

- Application:** Pumps cooling tower inhibitor proportional to tower load.
The longer the bleed solenoid is ON the more inhibitor is pumped.
- Setup:** User selects Inhibitor Pump relay & selects Bleed & Feed Special Control
User sets bleed solenoid relay number.
User sets % of bleed time 1-100%
- Operation:** Inhibitor Pump turns ON when Bleed Solenoid Relay turns ON.
Turns OFF when % ON time is exceeded in every 300 seconds.
If % of Bleed = 40%, Inhibitor Pump would be ON for 120 seconds in every 300 seconds of Bleed ON time.
- Notes:** Bleed & Feed use is limited to sites where the bleed OR the inhibitor pump is undersized and there not enough time between bleed periods to pump inhibitor.
Bleed then Feed is the preferred inhibitor feed method for sites, which do not have a make-up water meter.
Sites which have wide variation in make-up conductivity typically will have problems maintaining the target inhibitor level using Bleed & Feed.
Poor location of feed point and bleed take-off may result in inhibitor being pumped down the drain.
Bleed setpoint dead band should be set to 1% for short bleed and short feed periods.

2.6.2 Bleed then Feed

- Application:** Pumps cooling tower inhibitor proportional to tower load after the bleed solenoid turns OFF.
The longer the bleed solenoid is ON the more inhibitor is pumped.
- Setup:** User selects Inhibitor Pump relay & selects Bleed then Feed Special Control
User sets bleed solenoid relay number.
User sets % of bleed time 1-100%
- Operation:** Inhibitor Pump turns ON after Bleed Solenoid Relay turns OFF.
Turns OFF when % of Bleed ON time is exceeded.
If % of Bleed = 60% and Bleed was ON for 8.6 minutes, the Inhibitor Pump would pump for 310 seconds ($0.6 \times 8.6 \times 60$ sec/minute).
- Notes:** Bleed then Feed is the preferred inhibitor feed method for sites that do not have a make-up water meter.
Do not use Bleed then Feed at sites where the bleed or inhibitor feed pump is undersized. There will not be enough time between bleed periods to feed inhibitor.
Sites which have wide variation in make-up conductivity typically will have problems maintaining the target inhibitor level using Bleed then Feed.
Bleed setpoint dead band should be set to 1% for short bleed then feed periods.

2.6.3 Percentage Time

- Application: Base feeds chemicals by cycling a relay ON/OFF every 5 minutes.
Reliable method of control for static systems or where users manually adjust feed rates in response to on-site testing or process changes.
NOTE: Particularly useful where a contact set or flowswitch opens when the system is offline. % Time controls do NOT accumulate time when the interlock is OFF.
- Setup: User selects relay & selects the Percentage Time Special Control
User sets % of ON Time 1-100%
- Operation: Every 5 minutes, 300 seconds, the relay will turn ON for the user set %.
If % ON time = 24%, relay would be ON for 72 seconds in every 300 seconds.
If the interlocking contact set opens, the relay will turn OFF and % Time is suspended in it's current state, resuming when the contact set closes.
- Notes: Commonly used method to feed boiler chemicals where a contact set closes when the boiler is on-line. Typically boiler chemistry is verified by the operator, adjusting % time as required.

2.6.4 Prebleed – Lockout

- Application: Prebleed lowers the tower conductivity before a biocide is fed to prevent bleeding and subsequent biocide loss or dilution during biocide kill time.
Lockout prevents the bleed from operating during the biocide kill time.
Prebleed and Lockout execute on every timed event.
- Setup: User selects Biocide pump relay & selects Prebleed-Lockout Special Control
User sets Bleed Relay number. This is the relay that will be Prebled and then Locked Out every time a Biocide Event occurs on the Biocide pump relay.
User sets Lock-out time in minutes. Zero minutes = no lockout.
User sets Prebleed time in minutes. Zero minutes = no prebleed.
User sets prebleed conductivity OR 'none' if Prebleed is to be based on time only.
User sets prebleed conductivity value.
- Operation: Prebleed time starts when the timed event is scheduled on the Biocide relay.
Prebleed ends when the target conductivity is achieved or when the prebleed time completes.
Biocide turns ON for the user set time.
Lockout starts at the start of the Biocide timed event.
- Example: Biocide Event on relay No.4 starts at 07:00 for 30 minutes
Prebleed Relay No.2 is set for 30 minutes & 750uS on Conductivity Sensor 'E'.
Lockout time is set for 120 minutes.
At 07:00, Relay No.2 turns ON and the tower conductivity start to decrease.
At 07:20, the Tower Conductivity is 749uS.
At 07:20, Relay No.2 Bleed turns OFF and is Locked Out until 09:20.
At 07:20, Relay No.4 Biocide Pump turns ON
At 07:50, Relay No.4 Biocide Pump turns OFF
At 09:20, Relay No.2 can turn ON when the conductivity exceeds the Turn ON Setpoint.

2.6.4 Prebleed – Lockout continued

Notes: The time required to lower the tower conductivity is dependent on tower load. Subsequently, most biocides are fed early in morning when cooling towers are not loaded.
Typical Lockout times of four hours may be a problem if tower load increases. Since the bleed cannot operate, tower conductivity may exceed chemistry limits.

2.6.5 Captured Sample – Boiler Controls

Application: Captured Sample controls boiler blowdown using a conductivity sensor installed in a boiler's surface blowdown line, upstream of the blowdown valve.
An optional Fail-to-Sample sensor detects a failure to open the blowdown valve or an inadvertently closed isolation valve.

Setup: User selects Blowdown Valve relay & selects Captured Sample Special Control
User sets Sampling time in seconds, typically 30-60.
User sets Measure time in seconds, typically 60-120 seconds
User sets Blowdown time in seconds, typically 60-300 seconds
User sets Re-Sample delay in minutes, varies with boiler type and service from 30 minutes to 720 minutes (12 hours).
User sets location of optional Fail-to-Sample sensor, a contact closure input from 'none, through 'O' to 'Z'.

Operation: Captured Sample Blowdown Control is a four step process:
SAMPLE: The blowdown valve opens, purging the surface blowdown line and delivering a sample of boiler water to the conductivity sensor.
MEASURE: The blowdown valve closes, the sample at the sensor cools & at the end of the Measure period, the controller measures the conductivity.
If the conductivity is greater than the Turn ON Setpoint, go to Blowdown else go to Re-sample.
BLOWDOWN: The blowdown valve opens for a user set time then the controller goes to Measure.
RE_SAMPLE: The blowdown valve is closed for a user set time and then the controller goes to Sample.
FAIL-TO-SAMPLE: An optional normally open thermal switch, installed opposite the conductivity sensor, closes at nominally 200F, 95C. The controller checks the state of the Fail-to-Sample switch at the end of the Measure period. A closed Fail-to-Sample switch indicates a functioning blowdown.

Notes: As long as the measured conductivity is more than Turn ON Setpoint the controller will repeat the Measure-Blowdown-Measure-Blowdown cycle. The Measure period provides thermal compensation. The initial temperature is fixed by the boiler pressure. A rapid, but repeatable temperature drop occurs during the Measure period.

2.6.6 Time Modulation

Application: Cycles a chemical feed pump ON/OFF, decreasing the ON time as the controlling sensor approaches the Turn OFF setpoint
Typically used for pH control, reducing acid feed as the Turn OFF setpoint is approached.

Setup: User selects a relay & selects Time Modulation Special Control
User sets Time Period in seconds, minimum 60, maximum 600 seconds.

Operation: Relay ON time = $[(\text{Control} - \text{Turn OFF Setpoint}) / \text{Deadband}] \times \text{Period}$
where Deadband = Turn ON – Turn OFF setpoints.
Relay ON 100% of Period when Control is greater than Turn ON setpoint
Relay is OFF when Control is less than Turn OFF setpoint.

Example: Acid Pumps Turn ON = 10 and Turn OFF = 8. Period = 120 seconds
At pH ≥ 10 , Pump ON for 120 seconds in every 120 seconds
At pH = 9.5, Pump ON for 90 seconds in every 120 seconds
At pH = 9.0, Pump ON for 60 seconds in every 60 seconds
At pH = 8.5, Pump ON for 30 seconds in every 120 seconds
At pH ≤ 8.0 , Pump OFF

Notes: Time Modulation control is not applicable when the system response time is faster than 5x the Period. In the previous Example; If the measured pH moves from 10 to 8 in less than 300 seconds, Time Modulation may not improve control.

Process buffering, pump setting, feed point and system volume all affect the response to chemical feed.

Time modulation also works on Falling Setpoints.

2.7.7 Timed Cycling

Application: Large volume systems where the response to a chemical feed or control action is delayed in time.
Swimming pool pH, conductivity and ORP controls are typical applications.

Setup: User selects a relay & selects Time Modulation Special Control
User sets ON Time in minutes, minimum 1, maximum 360 minutes.
User sets Period in minutes, minimum 1, maximum 360 minutes.
Controller forces Period \geq ON Time.

Operation: Setpoint Controls turn ON the relay.
Time Modulation turns OFF the relay after ON Time minutes.
Time Modulation keeps the relay OFF for 'Period – ON Time' minutes.
During the OFF period, the system has time to respond to the ON Time feed.

Example: Time Modulation ON Time = 10 minutes, Period = 60 minutes
Brine feed is controlled on conductivity using a Falling Setpoint.
Conductivity setpoint control turns ON the Pool Brine feed relay.
After 10 minutes the Pool Brine feed turns OFF.
After another 50 minutes the Pool Brine feed turns ON for another 10 minutes if below the Turn ON setpoint or remains OFF if the conductivity is above the Turn OFF setpoint.

Notes: Condensate systems are also slow to respond to amine feed.
However the response time may vary with time of year and steam production.

2.7.8 Holding Time

Application: Prebleed Holding Time averages the value of a control over a user-defined period. Averaging lowers the effect of process transients and limits the effect of the delay between feed and measuring the effect of the feed. Control of amine feed by a pH sensor in the condensate return is a typical use of Holding Time control.

Setup: User selects relay & selects Holding Time Special Control
User sets averaging Period in minutes.
Minimum 30 and maximum 1440 minutes.
Holding Time controls use the controller data logs, limiting the control equation to a single analog sensor A..N.

Operation: Controller retrieves the controlling sensor data log average entries for the most recent Period. It averages the sensor value over the number of log entries and uses the average for setpoint control.
If the number of log entries x log rate is less than Period, the controller uses all of the available log entries.
If there are no log entries, the controller uses the current value of the sensor for control.

Notes: The number of samples used for control is the Period / Log Rate.
Log entries are an average over the Log Period.
You may choose to reduce the Log Period to increase response to transients or increase the Log Period to limit transient response.
The same effect may be achieved by altering the Holding Time Period.

2.7 Timed Events

Operation: Timed events load 'Time Owed' with ON Time when they are scheduled. Timed events always start on the minute. If a timed event is prevented from turning ON a relay, it will turn ON when the block clears or the flowswitch closes. Time Owed is loaded after Prebleed if the Biocide Pump relay has the Prebleed-Lockout Special Control selected. Clear Alarms on a relay zeroes Time Owed, ending a timed event and prebleed. Clear Alarms on a Locked Out bleed relay will end the Lock Out. Timed events can operate in parallel with other controls. For example, a water meter could add oxidant a low rate, proportional to load with a Timed event providing a weekly slug feed.

Number of Events: Each relay 1..10 can have up to 28 timed events.

Start Time: Each event has a user defined start time using a 24-hour clock with 1 minute resolution from 00:00 to 23:59.

ON Time: User set relay ON time from 1 to 1440 minutes per event.

Prebleed-Lockout: Each biocide control relay can have its own prebleed-lockout timing, user defined bleed relay and conductivity sensor. Support for user with multiple systems or cooling towers. For example: four towers with four bleeds and four biocide pumps, each of the four with it's own prebleed conductivity sensor.

Event Cycles: Each relay can select a 1, 7 or 28 day event cycle. You may elect to feed alternating organic biocides on a 28 day cycle, daily oxidant on a 7 day cycle and an every 4 hour sensor wash on a 1 Day cycle. One day cycle is always Day 1. Sunday is Day 1 for seven and twenty eight day cycles. Twenty Eight day cycles have the option to set the most recent Sunday to Day 1 using System/Configure command sequence.

Event Frequency: Varies with selected Event Cycle.
Allows user to quickly enter repeating events
1 Day Cycle: Once, Alternate Hours, Hourly
7 Day Cycle: Once, Alternate Days, Daily
28 Day Cycle: Once, Alternate Weeks, Weekly

2.8 Variable Cycles

- Problem:** Tower make-up conductivity may change rapidly.
If hardness tracks make-up conductivity, then controlling a cooling tower on tower basin conductivity may over cycle at low make-up conductivities and under cycle at high make-up conductivities.
Overcycling may exceed water treatment chemistry for scale control.
Undercycling wastes water & increases sewerage charges.
- Solutions:** Variable Cycles sets three ranges of cycles of concentration bleed control with ranging switched on make-up conductivity.
Variable Cycles also sets a maximum tower basin conductivity that overrides the cycle controls at high tower conductivities.
- Setup:** User selects relay, Configure and sets the Variable Cycles.
User selects relay, Variable Cycles and sets:
 Low Range: Makeup conductivity less than Low Range...
 Low Cycles: Controls the bleed at Low Cycles
 Med Range: Makeup conductivity between Low & Medium Range...
 Med Cycles: Controls the bleed at Medium Cycles
 High Range: Makeup conductivity between High and Medium Range...
 High Cycles: Controls the bleed at High Cycles
 Max Conduct.: Tower Conductivity greater than Max. Conduct controls the bleed on tower basin conductivity.
- Operation:** The controller overrides the Setpoint controls, modifying the setpoints in response to make-up and tower conductivity levels.
Users are able to view, but not modify ON & OFF Setpoints.
A 1% deadband applies to both Cycles and Maximum Conductivity setpoints.
A ratio control equation is required, in the form of E/F where E = Tower Basin conductivity and F = Makeup Conductivity.
If the control equation is not a ratio, the Special Control state will be set to OFFLINE.
- Notes:** Any ratio of analog sensors A..N may be used in a Varying Cycles control.
When setting Varying Cycles setpoints, calculate the time delay effect of system holding time on bulk system chemistry.
A change in makeup conductivity may take considerable time to modify the bulk chemistry of a cooling tower, particularly at low load.

2.9 Feed Verification

Controller Option. Field upgrade available.

Services: Calculates and logs inhibitor ppm based on make-up volume, cycles of concentration and volume of inhibitor fed.

Alarms on fail to feed inhibitor.

Calculates tank level, eliminates tank level sensing.

Application: Requires a feed meter on the output of the inhibitor feed pump.
Measures the make-up volume and feeds inhibitor based on user set control mode.

Meters the volume of inhibitor fed and calculates current ppm based on fixed cycles, meter cycles or bleed cycles on concentration

Reduces the inhibitor inventory by the volume of inhibitor fed.

Setup: User selects relay, Configure and sets the Feed Verification.

User selects relay, Feed Verification and sets:

Verify Meter: The water meter input O..Z connecting to the meter on the output of the inhibitor feed pump.

Inventory location: The analog sensor input A..N used to log the calculated inhibitor tank volume.

ppm location: The analog sensor input A..N used to log the calculated ppm

ppm method select:

Fixed Cycles: User sets a fixed number of cycles, default 3.500

Meter Cycles: User selects Bleed water meter input O..Z.

Uses the ratio of the tower make-up to the Bleed meter as concentration for ppm calculation.

Bleed Cycles: User select Bleed Relay number 1..10.

Use the value of the Bleed Relay control equation as concentration, assuming that the relay is controlled by the ratio of Tower to Make-up conductivity.

Operation: Assumes that the feed verification meter measures mL.
The controller calculates ppm based on the make-up volume fed from midnight, the ml of inhibitor fed and concentration from the user selected ppm method.
Failure to measure volume after the relay has been ON for 30 seconds, sets a Fail to Feed alarm on the Feed Verification meter.
Every 10mL of inhibitor fed reduces the inhibitor inventory. Inventory is calculated in Gallons. If the metric units switch is set, inventory is calculated in liters.

Notes: The default feed verification meter provides 1 pulse/mL.
Any type of meter can be used for metering inhibitor feed and should be calibrated for mL/pulse or contact closure.

PPM can be corrected for inhibitor concentration by calibrating the ppm analog input for the % active.

Do not calibrate the feed verification meter input for % active.

2.10 Priming

Setup: Select the target relay using either the keypad or the browser. Then select Diagnostics. Keypad users set Time Owed to 5 minutes on selecting Prime. Browser users can set the Prime time in minutes.

Operation: Time Owed > 0 minutes, immediately turns ON the relay.

SAFETY: Interlocked relays will not turn ON until the interlock contact set closes.

SAFETY: Blocked relays will not turn ON until the blocking relay turns OFF.

Relays OFF, alarmed on feed limit timers will not turn ON when primed. Clearing the relay alarm will also end Priming; requiring you to re-Prime.

Relays with Special Control set to Captured Sample will bypass Captured Sample timing, immediately turning ON the blowdown valve.

Ending Prime: Clearing Alarm on the relay ends Prime by setting Time Owed = 0.

Notes: Time Owed is also incremented by water meter volume feed controls and timed events and is zeroed by Clearing Alarms

3. Sensors

3.1 Compensation

Analog Sensors A..N

Type	Setup	Notes
Thermal	User selected thermal sensor A..N. User set %/degree compensation.	Applied to conductivity sensors. Zero at 70F or 20C, dependent on 'metric units' switch setting. The defaults are 0.97%/F or 1.746%/C
Rate-to-Volume	User selected water meter O..Z displays and logs resulting volume. User selected rate/minute or rate/hour	Typically a 4-20mA input proportional to gpm makeup rate or lbh steam production is converted to volume to feed ON/OFF based on volume & time setpoints.
Corrosion Rate	User set alloy number, default 1.00, Carbon Steel User selected conductivity sensor A..N. corrects corrosion rate for conductivity.	Controller sets alloy to default and conductivity sensor to 'none' on CR driver installation. Conductivity sensor optional. Remove driver to remove compensation.
Manual Entry		Logs the results of ppm testing or any analog value. Any analog input without a driver card or with an IO, 4-20mA output driver, may be used for Manual Entry. Remove by setting compensation to 'none'
Calculated	Feed Verification calculated ppm log.	Remove by setting to 'none' in Feed Verify control.
Inventory	Feed Verification calculated tank volume log.	Remove by setting to 'none' in Feed Verify control.

Water Meter Sensors O..Z

Switching from Contact Set to Water Meter clears log.

Type	Setup	Notes
Contact Head	User set volume/contact	Contact Head compensation turns ON software debouncing. Volume counts on contact closure. Contact opening ignored.
Turbine	User set 'K' factor, pulses/unit volume	Counts pulse on falling edge, 400Hz max. Ignores rising edge.

Contact Sets, Flowswitches, Fail-to-Sample Sensors O..Z

Switching from Water Meter to Contact Set clears log.

Type	Setup	Notes
Contact Set	User selects Contact Set	Contact sets are ON when closed and OFF when open. ON time is logged. Contact sets used for interlocking, prevent relays from turning ON when contact set is OFF, or open.

3.2 Calibration

3.2.1 Single Point Calibration

All inputs A..Z with the exception of 4-20mA, type 'CI' inputs, are single point calibrations. Calibration of contact set inputs is blocked.

SENSORS A..N:

Conductivity, Calculated: Sensor GAIN is adjusted so that the sensor value matches the user's calibration value.

Temperature, pH, ORP, Corrosion Rate: Sensor OFFSET is adjusted so the sensor value matches the user's calibration value.

Inventory, Manual: Sensor OFFSET is set so the sensor value matches the user's calibration value. Since the GAIN on these inputs is zero, the OFFSET is the input value for control and logging.

WATER METERS: The user calibration value is Volume/contact for contact head meters and 'K' factor (Pulses per unit volume) for turbine and paddlewheel meters.

During calibration users have the option to Reset to Factory, refer to Section 3.2.3 for Factory GAIN & OFFSET values.

If the calibration OFFSET or GAIN is outside fault limits, users are offered the option to OVERRIDE. OFFSET or GAIN outside of the fault limits typically indicates a sensor, cabling or driver fault.

Users have the option to enter OFFSET and GAIN by selecting Sensor then Configure

The value of a sensor = Measured Level (mV) x GAIN + OFFSET.

This value may be modified by sensor compensation.

Compensation (Temperature, Rate-Volume, Corrosion Rate...) is applied after GAIN & OFFSET.

3.2.2 Two Point Calibration

Two point calibration is limited to type 'CI', the dual 4-20mA input driver.
 There are no fault limits on GAIN or OFFSET for 'CI' drivers.
 Reference Driver_CI.doc. See Appendix A for list of supporting documents.

3.2.3 Reset to Factory

Installed sensor driver cards & reconfigured water meters are Reset to Factory on Power on.
 User selected Reset to Factory loads the GAIN, OFFSET set from the following table.

Sensor Type	Driver Type	Factory Gain	Factory Offset	Fault MAX	Fault MIN
Boiler – Condensate Conductivity Type = Boiler Type = Condensate	B	2.0 8.0	-15 -90	GAIN 10 12	GAIN 0.5 3.0
Calculated Value		100	0	none	none
Conductivity Range >100uS Range <100uS	CT	5.6 0.4	-35 -10	GAIN 10 0.55	GAIN 2.5 0.25
Corrosion Rate	CR	1	0	none	none
4-20mA Current Input	CI	1	0	none	none
Manual Entry		1	0	0	0
ORP - pH Type = pH Type = ORP	OP	0.017 -1	7 0	OFFSET 8 50	OFFSET 6 -50
Temperature US units Metric units	CT	0.18 0.1	-459.4 -273	OFFSET -430 -253	OFFSET -590 -293
Water meter Contact Head Turbine		100 100		None	none

4. System Configuration

4.1 Power/Relay and I/O Modules

Controllers consist of two circuit boards installed on a metal frame in a non-metallic enclosure with optional driver cards and communications accessories.

Controller Part	Status	Services
<p>PR10 Module</p> <p>or</p> <p>PR5 Module</p>	<p>Required</p> <p>1 per controller</p>	<p>AC input and ON/OFF power relay terminal blocks.</p> <p>Alarm relay and field wiring terminals.</p> <p>Power relay and Control Fusing, surge suppression and snubbing on relays 2-5 and 7-10.</p> <p>NEON relay ON indicators. Hardware watchdog.</p> <p>PR10: 10 Power relays, Eight of ten with Power Open-Power Closed terminals. Fused in two groups of 5 @ 6.3 Amps ea.</p> <p>Controller alarms on loss of each relay fuse, Current transformer measures total load current.</p> <p>PR5: 5 Power relays, Four of five with Power Open-Power Closed terminals. Fused at 6.3 Amps.</p> <p>Controller alarms on loss of relay fuse.</p>
<p>M7 Module</p> <p>or</p> <p>M14 Module</p>	<p>Required</p> <p>1 per controller</p>	<p>4 lines x 20 character backlit LCD supply & 5 key keypad.</p> <p>15-22VDC output for current loops and three wire water meters.</p> <p>Automatic controller re-configuration on sensor driver card installation and/or removal.</p> <p>M7: 6 Digital inputs, individually configurable as water meters or dry contacts. Three-dual and one single analog input sockets.</p> <p>M14: 12 Digital inputs, individually configurable as water meters or dry contacts. Seven dual analog input sockets.</p>
<p>Modem</p>	<p>Optional</p>	<p>V.90 56K Data Fax Modem, with 12VAC power cube.</p> <p>Controller-to-Modem serial flat cable, DB9 to polarized IDC 10, socket.</p>

4.2 Installing Sensor & 4-20mA Drivers

There are 6 types of optional driver cards.

Four of the six types are provided as either a single or dual I/O card.

Driver Cards	Services
B , Boiler – Condensate Single & Dual	Single or dual boiler – condensate sensor driver. Each sensor may be set to boiler or condensate. M7: Max 7 sensors, M14: Max 14 sensors.
CI , Current Input Dual	Loop powered 4-20mA input, thermally fused, polarity protected. Loop active LEDs at more than 3.5mA M7: Max 7 inputs, M14: Max 14 inputs.
CR , Corrosion Rate Single & Dual	Single or dual sensor. Support for steel, copper, admiralty and zinc or dual metals on dual CR drivers. M7: Max 7 sensors, M14: Max 14 sensors.
CT , Conductivity – Temperature	Sensor driver for single conductivity-temperature sensor. Conductivity and temperature logged alarmed & available for control. Two ranges <100uS & >100uS. M7: Max 3 sensors, M14: Max 7 sensors
IO , 4-20mA Output Single & Dual	DC isolated loop or controller powered. User configurable controls. Manual & Auto modes. Interlocked loops go to 4mA. M7 & M14: Max eight 4-20mA outputs.
OP , ORP – pH Single & Dual	Single and dual sensor. User configurable to pH or ORP. Dual cards may be user configured for one pH & one ORP or dual pH or dual ORP. M7: Max 7 sensors, M14: Max 14 sensors.

Driver installation-removal sequence:

1. Unplug or turn the controller power OFF. Do not install or remove driver cards with the controller power ON.
2. If removing a driver, compress the locking tangs on the nylon card pin and pull the end of the driver up over the locking tangs. Pull the driver out of its socket horizontally, removing the driver.
3. Install a driver, aligning the driver socket with the header on the M7 or M14 module and pushing the card down on the installation pin until the pin locks the driver in place.
4. **CAUTION:** Verify that the driver is aligned with the white footprint on the M7 or M14 module. Incorrectly aligned cards will immediately fail both the driver and M7 or M14 on power up.
5. Connect sensor(s) to the driver card.
6. Power up the controller and view the present value of sensor, calibrating if necessary.
7. Corrosion Rate drivers require 16 seconds to measure. All other drivers will measure sensors within a few seconds.

4.3 System Settings

Accessed by System / Configure. Requires Admin password

Parameter	Function	Default	Access
Site Name	Location Name, maximum 17 characters	-	Browser
Site Location	System Name, maximum 17 characters	-	Browser
This Sunday Day1	YES: 28 Day Cycle biocide cycle reset day 1 to the most recent Sunday.	NO	Browser
Metric Units	YES: Driver temperature inputs immediately Celsius. FV calculations immediately in Liters 4-20mA inputs, which measure temperature, are unaffected. Temperature compensation factors for conductivity unmodified. Corrected if compensation set to 'none' then reset to Thermal. On Reset & New Type, water meters default to Liters	NO	Browser & Keypad
Keypad Passwords	YES: Keypad users prompted for userid whenever modifying controller parameters	NO	Browser & Keypad
Alarm Opens Contacts	YES: Alarm contacts default to closed in the non-alarm state. Alarm, loss of power or cable break, opens alarm contacts	YES	Browser & Keypad
Load Configuration	YES: Shuts controller down and loads the most recent Save Configuration on restart. Factory Default is loaded if user has never executed Save Configuration.	NO	Browser & Keypad
Save Configuration	YES: Shuts controller down. Takes about 5 minutes to write controller configuration to FLASH memory then restarts controller.	NO	Browser & Keypad
System restart	Shuts controller down & restarts. Checks for new & removed driver cards.	NO	Browser

4.3 Module Testpoints

Supplied for bench testing only, not intended for field use.

A/D inputs will scan too quickly for DVM's. Constantly changing levels indicate that the MUX and driving logic is functional.

Unregulated 15-22VDC supply accessible both before and after Thermal Fuse

1000:1 Current Transformer level =100mV/A after rectification.

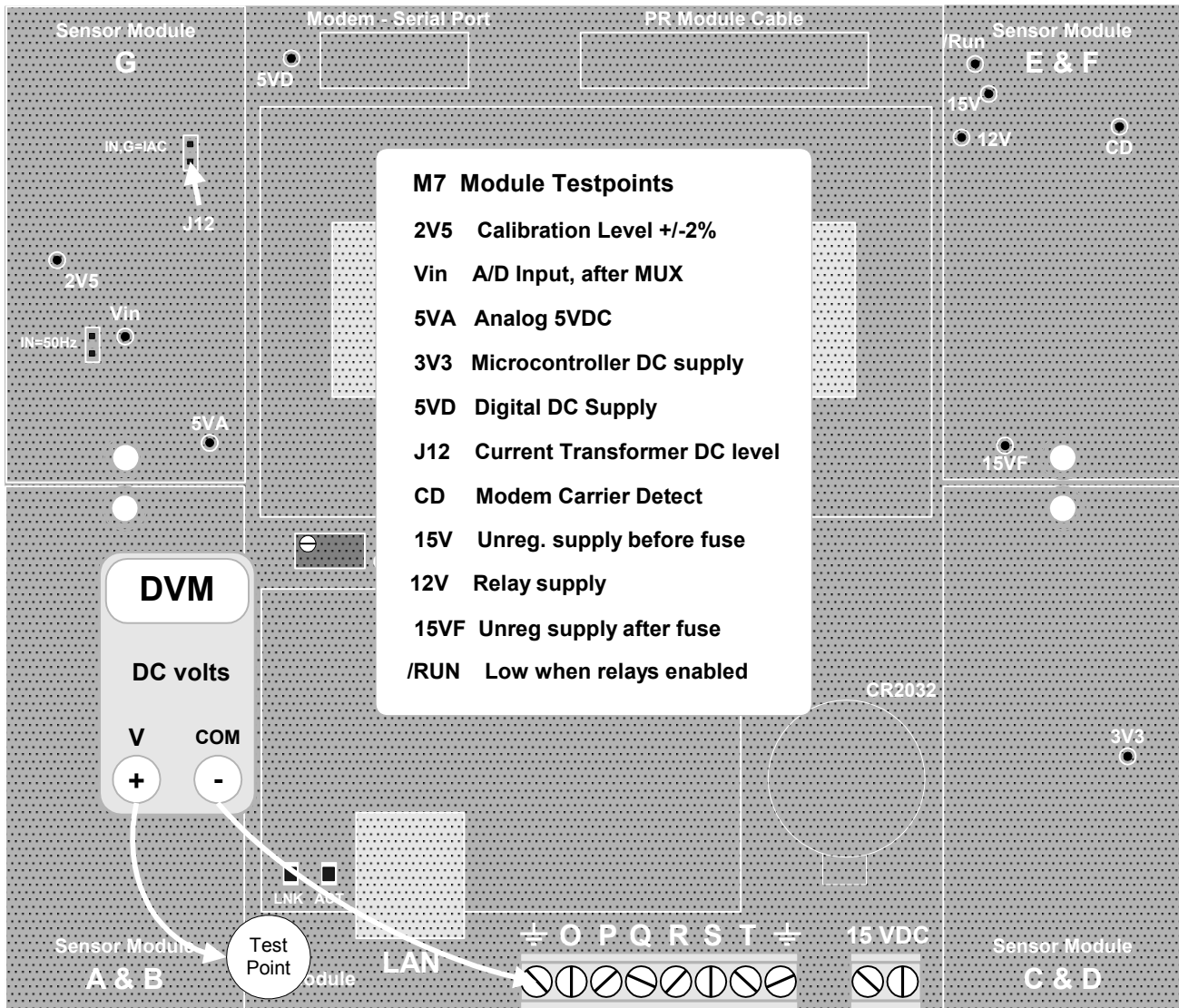

4.3 Module Testpoints continued

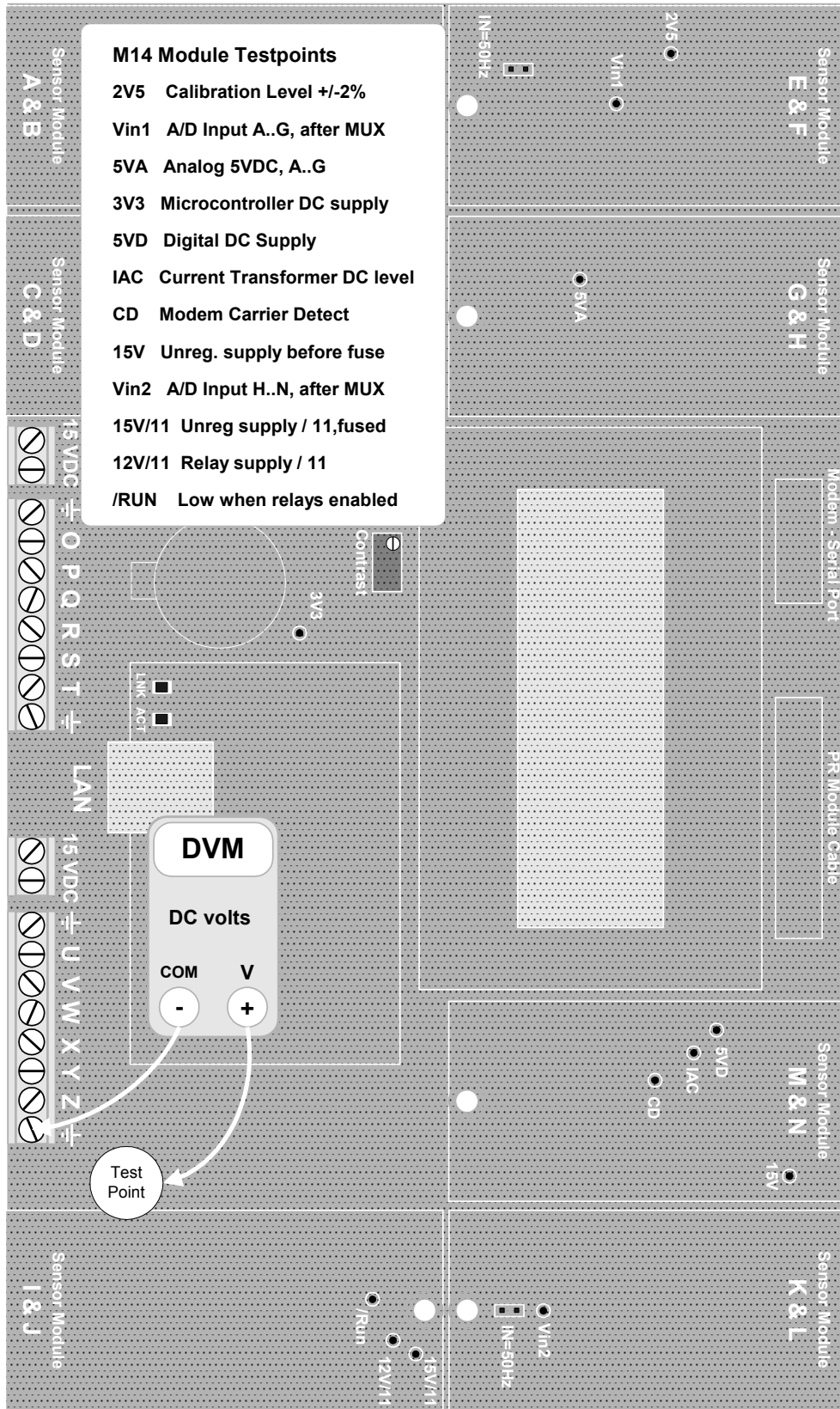

4.3 Module Testpoints continued

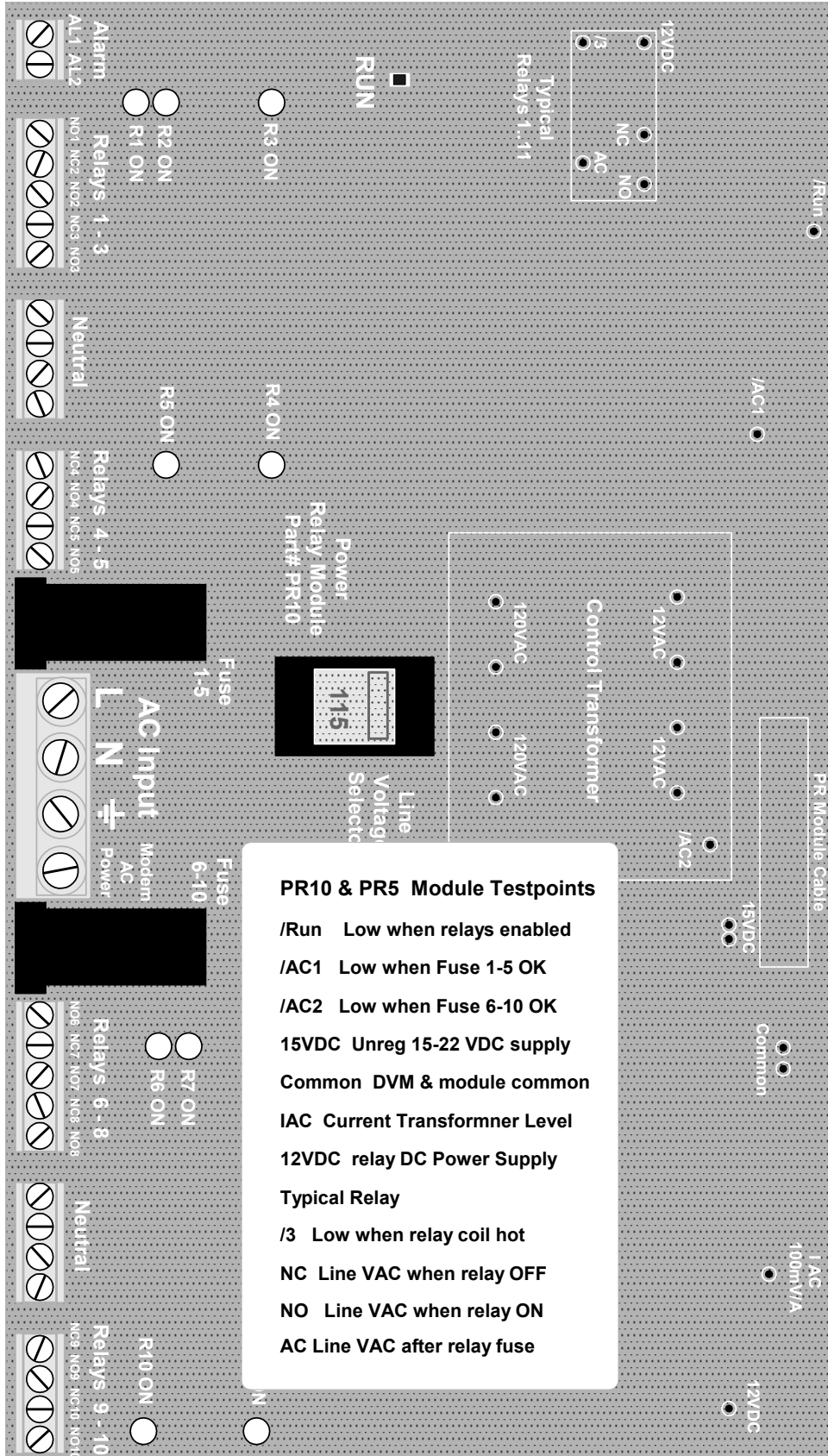

Appendix A: Resource Index

Spare parts, documentation: [www.](#) [text required]

Telephone Support: [text required]

Documentation

Type	Subject	Filename
Manual	M714 Technical Manual	M714_Tech
Manual	M714 Keypad – LCD Manual	M714_User
App note	CS Command: Telnet State Stream API information for non-browser user interfaces	AN_T001
App note	AM Command: Admin – Manufacturer Not in the public domain	AN_T002
App note	Controller Communications: URL Encoding – Telnet API information for non-browser user interfaces	AN_T003
App note	Browsing a controller not connected to a LAN	AN_T004
B Driver	Boiler-Condensate driver technical manual	Driver_B
CI Driver	Current Input driver technical manual	Driver_CI
CR Driver	Corrosion Rate driver technical manual	Driver_CR
CT Driver	Conductivity – Temperature driver technical manual	Driver_CT
IO Driver	Current Output driver technical manual	Driver_IO
OP Driver	ORP – pH driver technical manual	Driver_OP