

# DULCO flex Control (DFYa)

Intelligent peristaltic metering pump!



ProMinent®

The new **Dulco flex Control DfYa** metering pump adds an intelligent peristaltic offering to our established line of ProMinent pumps

This new design of peristaltic pump is controlled electronically via an HMI controller thus allowing for greater turndown in our **DulcoFlex** pump series. All the benefits of a peristaltic pump are retained including off-gassing fluids, high viscosity and abrasive media, and shear-sensitive liquids.

Like the **DFXa**, the **DFYa** offers simple and easy hose replacement via the HMI controller. When the hose needs replaced, the pump displays instructions for the user to step-through the replacement process.

## Features & Benefits

- Control via contact, batch, manual or analog modes
- Adjustment of the metering rate directly in gph or l/h
- Connection to process control systems via BUS interfaces, such as PROFIBUS®, Profinet or CANbus
- Large illuminated display
- Pump is available as an FDA design
- Reverse flow is possible
- Viscosities to 40,000 cPs

# DULCO flex Control (DFYa)

## Technical data

Capacity Data									
Pump Version	Capacity at Maximum Backpressure				Max. speed rpm	Connector size in	Suction Lift		Shipping Weight lbs (kg)
	GPH ( $\pm 10\%$ )	(L/H) ( $\pm 10\%$ )	PSIG	(bar)			ft	(m)	
<b>DULCO flex Control (DFYa)</b>									
08410	108.3	(410)	116.0	(8)	80	3/4"	26.25	(8)	66 (30)
04410	108.3	(410)	58.0	(4)	80	3/4"	26.25	(8)	66 (30)
02410	108.3	(410)	29.0	(2)	80	3/4"	26.25	(8)	66 (30)

**Tube material:** .....NR (Natural rubber)  
 .....NBR (Nitrile rubber), NBR-A (Nitrile rubber FDA approved)  
 .....EPDM  
 .....Hypalon  
**Pre-primed suction lift:** .....26.25 ft (8 m)  
**Rollers/shoes:** .....Rollers  
**Metering reproducibility:** ..... $\pm 2\%$  with retracted tube (after approx. 500 revolutions)  
**Electrical connection:** .....100 - 230 V  $\pm 10\%$ , 50/60 Hz  
**Power consumption:** .....Max. 400 W  
**Degree of protection:** .....IP 55  
**Permissible ambient temperature:** ..14 - 113 °F (-10 - 45 °C)  
**Optional relay modules:** .....Fault indicating relay - 230 V AC - 8 A  
 .....Fault indicating relay +Pacing relay - 24 V DC - 100 mA  
 .....0/4-20 mA output + fault indicating/ pacing relay - 24 V DC - 100 mA

Capacity data represents minimum values, tested using water at 68 °F (20 °C) (room temperature)

## Dimensional Drawing

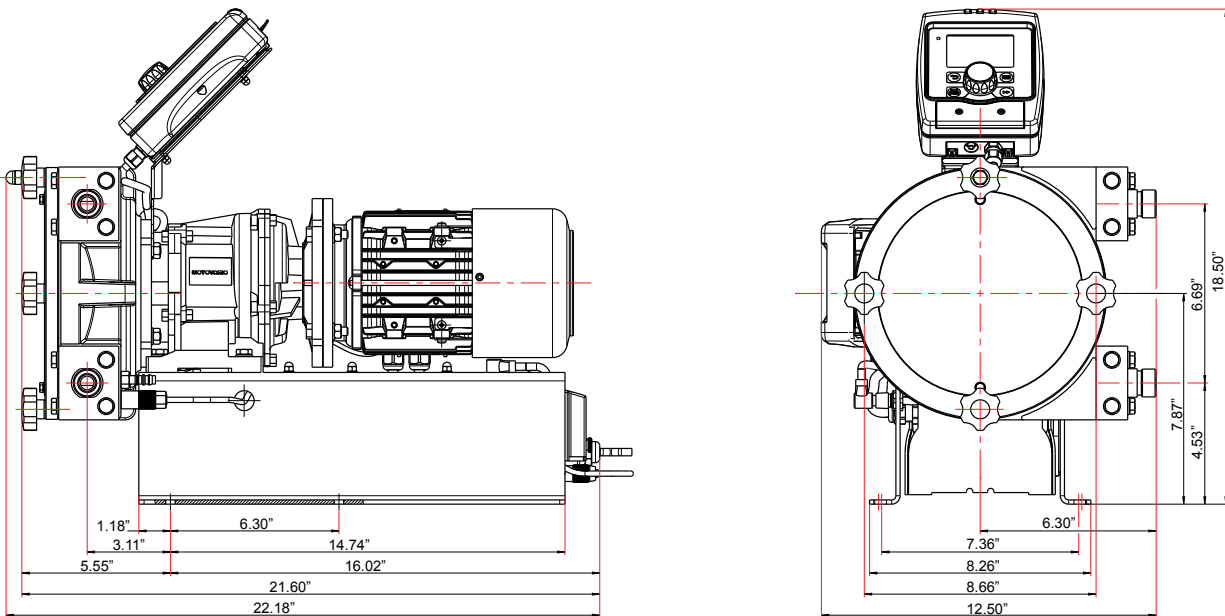

Note: All above measurements are in inches

© 2020 ProMinent Fluid Controls, Inc. · All Rights Reserved · PN: 7750019 · DULCO\_flex\_Control\_DFYa.indd rev2 · 3/17/2021