

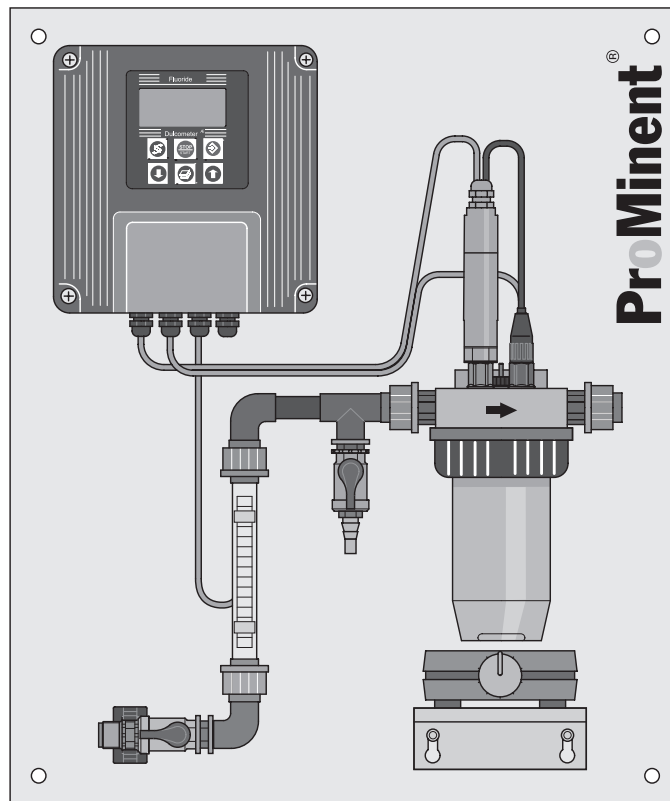

Operating Instructions

Fluoride Meter Mounted on Panel



Affix type identification plate here!

This operating instructions applies only when used in conjunction with the following operating instructions:
 Operating Instructions DULCOMETER® D1C Part 1: Mounting and installation instructions for wall-mounted and control panel-mounted devices
 Operating Instructions DULCOMETER® D1C Part 2: Adjustment and Operation, Measured variable fluoride
 Operating Instructions DULCOTEST® measuring transducer 4-20 mA FP V1 and FP 100 V1
 Recommendations for handling and servicing fluoride sensor FLEP 010 SE/FLEP 0100 SE
 Recommendations for handling and servicing pH and redox (ORP) combination probes (for REFP SE),

**Please completely read through these operating instructions first! · Do not discard!
 The operator shall be liable for any damage caused by installation or operating errors!**

Imprint:

Operating Instructions Fluoride Meter Mounted on Panel
© ProMinent Dosiertechnik GmbH, 2002

ProMinent Dosiertechnik GmbH
Im Schuhmachergewann 5-11
69123 Heidelberg
Germany

info@prominent.com
www.prominent.com

Subject to technical alteration.
Printed in the F.R. Germany

	Page
General User Instructions	4
1 About the fluoride measurement station	5
2 Safety instructions	5
3 Scope of delivery	5
4 Layout and Function	6
4.1 Design	6
4.2 Function	6
4.2.1 Theoretical background of fluoride measurement	6
4.2.2 Features of the probe	7
5 Assembly and Installation	8
5.1 Assembly	8
5.2 Installation, hydraulic	9
5.2.1 Fluoride measurement station	9
5.2.2 Probes	10
5.3 Installation, electrical	10
5.3.1 Measured value transmission	11
5.3.2 Limit value monitoring	11
5.3.3 Flow monitoring	11
5.3.4 Probes	12
5.3.5 DULCOMETER® D1C meter supply voltage	12
6 DULCOMETER® D1C meter and PLC settings	13
6.1 Measured value transmission	13
6.2 Limit value monitoring	14
6.3 Flow monitoring	16
7 Commissioning	17
7.1 Setting up limit value contact	17
7.2 Function test	17
7.3 Running in fluoride probe	18
7.4 Calibrating fluoride probe	18
7.4.1 Calibration with photometer	18
7.4.2 Calibration with DULCOMETER® D1C or pH/mV meter	18
8 Maintenance	22
9 Troubleshooting	23
10 Decommissioning	24
11 Spare parts and accessories	25
Appendix	26

General user instructions

Please read through the following user instructions! Familiarity with these instructions will help you get the most use of this operating instructions manual.

The following are highlighted in the text:

- Enumerations
- ▶ Handling instructions

Operating guidelines:

NOTE

Notices are intended to make your work easier.

and safety instructions, identified with pictograms:



WARNING

*Describes a potentially hazardous situation.
Non-observance of instructions can result in damage to property!*



CAUTION

Describes a potentially dangerous situation. If not avoided, could cause slight or minor injury or damage to property.



IMPORTANT

Describes a potentially dangerous situation. If not avoided, could cause damage to property.

1 About the fluoride measurement station

The fluoride measurement system is used to monitor fluoride metering systems in waterworks via online detection of the fluoride concentration. With appropriate circuitry the device can trigger an alarm if a pre-set limit value is exceeded. It is thereby an alternative to conventional, sequentially operating fluoride analysers.

Online detection has decisive advantages over fluoride analysers:

- Simple and compact installation
- Rapid commissioning
- No use of chemicals such as buffer solutions and therefore no pumps required to meter them
- Low operating costs

2 Safety instructions



IMPORTANT

- ***The fluoride measuring system may only be used to monitor fluoride metering in waterworks!***
- ***The fluoride measuring system may only be used in accordance with the technical data and specifications given in this operating instructions!***
- ***All other applications and modifications are prohibited!***
- ***The fluoride measuring station may not be used for the automatic control of the fluoride concentration in potable water.***
- ***The fluoride measuring system is to be operated by appropriately trained and authorised personnel only.***
- ***You must also observe the operating instructions for the individual components!***

3 Scope of delivery

Check that the delivery is complete.

The fluoride measuring system is fully mounted on a panel and pre-wired:

- Stopcock (for intake)
- Flow meter 0-60 l/h
- Maximum limit contact
- Sampling tap
- In-line probe housing DLG IV
- DULCOMETER® D1Ca fluoride controller
- DULCOTEST® measurement transducer 4-20 mA FP V1 for measuring range 0-10 ppm and measurement transducer 4-20 mA FP 100 V1 for measuring range 0-100 ppm
- Fluoride probe DULCOTEST® FLEP 010 SE/FLEP 0100 SE
- RE-electrode DULCOTEST® REFP SE
- Temperature probe DULCOTEST® Pt 100 SE
- Measuring line for Pt 100
- 230 VAC magnetic stirrer Euro-plug or 115 VAC USA-plug
- Magnetic stirring rod

Supplied loose:

- Connector set 8x5 PCE
- 2 Inserts d16 (adapter for adhesive bushing)
- 2 Union nuts G3/4
- 2 Adapter sets single

With documentation:

- Operating Instructions DULCOMETER® D1C Part 1: Mounting and installation instructions for wall-mounted and control panel-mounted devices
- Operating Instructions DULCOMETER® D1C Part 2: Adjustment and Operation, Measured variable fluoride
- Operating Instructions Fluoride Meter mounted on panel
- Recommendations for handling and servicing fluoride sensor FLEP 010 SE/FLEP 0100 SE
- Operating Instructions DULCOTEST® measuring transducer 4-20 mA FP V1 and FP 100 V1
- Recommendations for handling and servicing pH and redox (ORP) combination probes (for REFP SE)

4 Layout and Function

4.1 Design

Fig. 1
Design

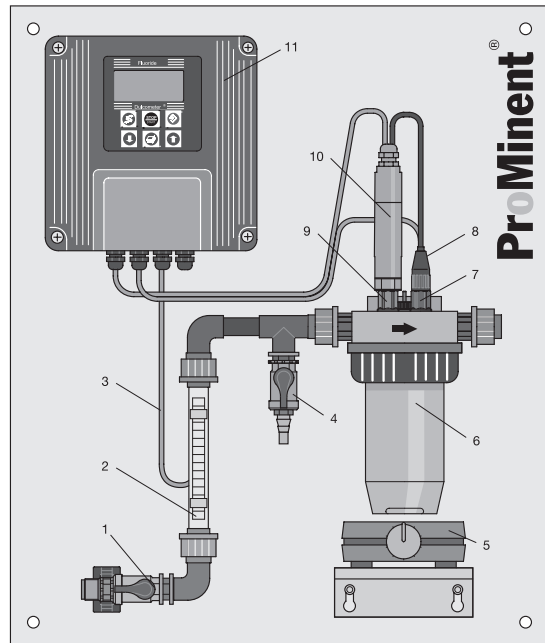

- 1 Stopcock
- 2 Rotameter
- 3 Limit contact
- 4 Sampling tap
- 5 Magnetic stirrer
- 6 DLG IV in-line probe housing
- 7 REFP SE reference electrode
- 8 Pt 100 temperature sensor
- 9 4-20 mA FP V1 measuring transducer
- 10 FLEP fluoride probe
- 11 DULCOMETER® D1C fluoride measuring device

3626_3

4.2 Function

The system measures the F^- ions from e.g. Na_2SiF_6 (disodium hexafluosilicate) or NaF. Measurement requires no chemicals, i.e. it does not use the conventional pH and ion strength adjustment buffers (TISAB - Total Ionic Strength Adjustment Buffer) used in fluoride measurement.

Depending on the fluoride concentration a potential difference is formed between the fluoride probe and the reference electrode. This potential difference is converted by the measuring transducer into a 4...20 mA signal and transmitted to the meter. This then calculates the fluoride ion concentration from the potential difference and the calibration data. The temperature is also measured and the fluoride measurement signal is automatically temperature compensated by the measurement device. The fluoride ion concentration is displayed in ppm together with the temperature in the permanent display 1 of the DULCOMETER® D1C measurement device.

4.2.1 Theoretical background of fluoride measurement

To obtain a better understanding of the processes involved in fluoride measurement it is worth taking a brief look firstly at the theoretical background and then at the features of the probe.

The relationship between potential and fluoride ion concentration is expressed by the so-called NERNST equation:

$$E = E_s + S \cdot \lg a(F^-)$$

where: E = measured potential

E_s = standard potential (constant)

S = electrode slope ($\frac{RT}{ZF} = -59,16 \text{ mV /Dec at } 25 \text{ }^\circ\text{C}$)

$a(F^-)$ = fluoride ion activity

The NERNST equation shows a logarithmic relationship between the fluoride ion activity and the measured potential, so that with a semi-logarithmic graph ideally at 25 °C a straight line with slope S (fluoride probe slope) = -59.16 mV per concentration decade (or a change in concentration by a factor of 10) and the corresponding standard potential on the y axis section E_s (potential axis E[mV]) is obtained. These two values are required by a device in order to calculate the fluoride concentration on the basis of a measurement of a potential potentiometric measurement. The following diagram shows a typical real calibration line for the range between 0.5 and 2 ppm fluoride in 1 g/l Na_2SO_4 solution with no other additives:

Fig. 2

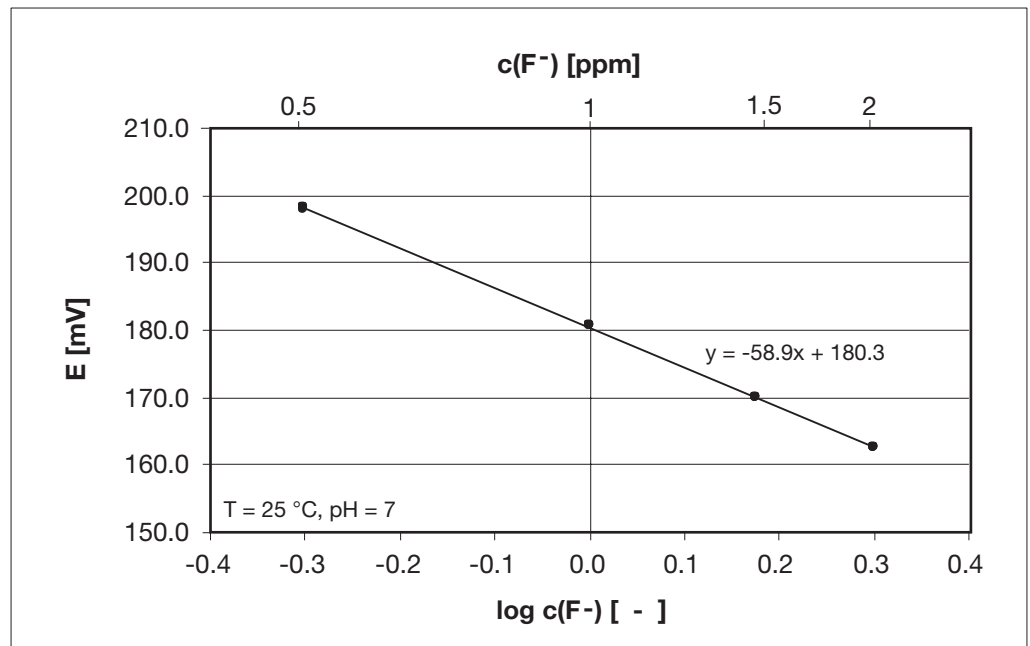

The fluoride ion activity is dependent on the fluoride content itself and on the ionic composition (ionic strength) of the sample water. In very low concentrations of less than 10^{-4} mol/l the activity is equal to the concentration. In the event of an e.g. high but constant ion strength the activity is directly proportional to the concentration.

These two variants can be used in fluoride measurement by measuring directly in water with low fluoride content or by using one of the various ion strength adjustment buffers. These buffers are used to maintain a constant ionic strength independently of the sample water. They also adjust the pH value to a fixed level and (depending on the water composition) liberate complex bound fluoride ions.

NOTE

A concentration is generally given in mol/l or in ppm (\triangleq mg/l). The following therefore apply in the case of fluoride:

1×10^{-4} mol/l	1.90 ppm
1×10^{-5} mol/l	0.19 ppm
1×10^{-6} mol/l	0.019 ppm

4.2.2 Features of the probe

General probe features

Function method The ion selective layer of a fluoride electrode generally comprises a europium-doped lanthanum fluoride single crystal (LaF_3), which forms a solid ion conductor for fluoride ions. Depending on the fluoride concentration in the sample water a potential is generated which is detected by an internal electrode and measured against a reference electrode (an electrode with a fixed reference potential). Only free fluoride ions are measured, not complex bound ions. Undissociated free acid (HF) is not displayed.

pH dependency and interfering substances

A fluoride electrode is in principle a highly selective sensor with a linear range of approx. 10^{-6} mol/l up to saturation. Due to the OH^- cross-sensitivity of the fluoride electrode, the pH value of the solution and the presence of certain complex-forming ions influence the measurements.

High pH values > 9.5 influence the signal and the slope at concentrations in the lower ppm range, i.e. the calibration line flattens out at this point (shallower slope) and the sensor is therefore outside its linear range.

Low pH values < 5 reduce the concentration of free fluoride ions by forming free, undissociated HF acid and/or the complex $[\text{HF}_2]^-$. There also exist fluoro-complexes of Al^{3+} , Fe^{3+} and Si^{4+} , which also draw fluoride from the sample water. Fluoride also forms a low soluble salt with Ca^{2+} . These interfering substances all contribute to reducing the amount of fluoride that can be detected.

NOTE

**Special features of the ProMinent® FLEP 010 SE/FLEP 0100 SE fluoride probe
(A summary table can be found in "Recommendations for handling and servicing fluoride sensor")**

Slope As already described above, the semi-logarithmic graph of the concentration against the potential, ideally at 25 °C, shows a straight line with a slope of -59.16 mV/Dec. In reality this value is rarely achievable and is generally somewhat lower.

Temperature influence Temperature changes in the sample water have a significant effect on the signal. On the one hand they lead to a change in the slope of the calibration lines. On the other hand they cause a shift of the standard potential E_s , which reflects the potential change of the whole meter.

T [°C]	0	5	10	15	20	25	30	35
S [mV/Dec.]	- 54.2	- 55.2	- 56.2	- 57.2	- 58.2	- 59.2	- 60.1	- 61.1

As shown previously in the NERNST equation (chapter 4.2.1), the slope of the fluoride probe has a linear relationship to temperature:

The DULCOMETER® D1C measuring device automatically compensates both effects when a temperature sensor (Pt 100) is connected.

Conductivity of sample water As the measurement system works without TISAB additives, the conductivity of the sample water has a certain influence on the signal. A change in the conductivity by several hundred $\mu\text{S}/\text{cm}$ creates only a minimal parallel shift of the calibration line along the potential axis, i.e. the slope of the fluoride probe remains unaffected down to 100 $\mu\text{S}/\text{cm}$. At low conductivity the response time lengthens (see below).

Response time The response time $t_{95}(\text{up})$ of the fluoride probe in sample water with a conductivity of more than 300 $\mu\text{S}/\text{cm}$ is less than 60 s. This time is affected by the conductivity of the sample water and the fluoride concentration. At the detection limit (approx. 10^{-6} mol/l fluoride) the response time $t_{95}(\text{up})$ can be several minutes.

5 Assembly and Installation

5.1 Assembly



IMPORTANT

Ensure that the flow meter is installed vertically to prevent the float from becoming wedged inside the flow meter.

When attached to the wall the system should be easy to operate and read. The sampling points should be close to the fluoride measurement system to minimise the hydraulic dead time of the measurement.

The board is attached to the wall with four screws. It must be installed vertically to ensure that the float in the flow meter does not rub against the walls of the device, or tip and become stuck. If necessary, use spacers to adjust the board to the correct position.

Safe ambient operating conditions:

Temperature: 1...40 °C (air)
Climate: max. 90 % rel. humidity, non-condensing
Enclosure rating: IP 65

5.2 Installation, hydraulic

5.2.1 Fluoride measurement station



IMPORTANT

- Use a pressure release valve to limit the pressure of the sample water to max. 1 bar. The maximum operating pressure of the in-line probe housing will otherwise be exceeded.
- If water is fed into a tank, the backpressure must not exceed 1 bar. The maximum operating pressure of the in-line probe housing will otherwise be exceeded.
- If feeding into the drains at atmospheric pressure, insert an upward-pointing 90° elbow into the outlet pipe to preserve the atmospheric pressure in the system (see fig. 3). The reference electrode may otherwise be damaged.

Installation materials included in the delivery:	Order no.
Connector set 8x5 PCE	817048
2 off Insert d16 DN 10 PVC2	356572
2 off Union nut G3/4 DN 10 PVC	356562
2 off Adapter set single M20 x 1.5 – G3/4 PCE	740585

The following connector kits are available from ProMinent:	Order no.
• 6x4 PCE connector set	817060
• 12x9 USA PCE connector set	740160
• 12x9 PCE connector set	817049
• 12x6 PCE connector set	791040
• PE hose	(on request)

- ▶ Connect the fluoride measurement station to the pressure relief valve for the water sampling station via a hose or a fixed pipe (Note the direction of flow! Arrow on DLG)
- ▶ Attach a drainage pipe to the in-line probe housing.

Testing the hydraulic installation of the fluoride measurement station:



IMPORTANT

The sample water must be free of air bubbles for reliable measurement.

- ▶ Set the flow at the stopcock to 20...60 l/h.
- ▶ Check the system for leaks (liquid escaping, permanent air bubbles in the DLG) and tighten threaded connectors if necessary.

Check system for vacuum

Open sampling tap (hold a container ready).
If water flows out of the sampling tap there is no vacuum in the system.
If air is sucked in, there is a vacuum. In this case, twist the drainage pipe in the 90° elbow upwards:

Fig. 3

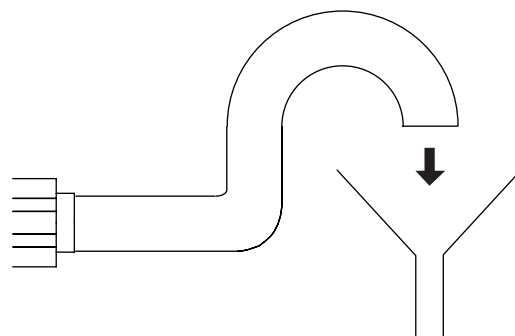

5.2.2 Probes



IMPORTANT

Observe the fluoride probe handling instructions.

- ▶ Close stopcock
- ▶ Remove the three plugs from the DLG in-line probe housing (see Fig. 4):

Fig. 4

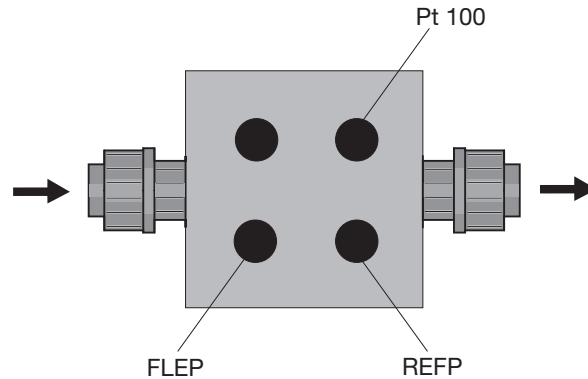

- Pt 100** ▶ Screw in the Pt 100 by hand into the back right-hand threaded bore and carefully tighten the threaded connection with a spanner (size 17 mm).
- Reference electrode** ▶ Screw in the REFP SE by hand into the front right-hand threaded bore and carefully tighten the threaded connection with a spanner (size 17 mm).
- Fluoride probe** ▶ Hold the FLEP fluoride probe by the plug and shake lightly towards the floor like a mercury thermometer to remove any air bubbles that may be clinging to the LaF_3 crystal inside.
 - ▶ When screwing into the front right of the in-line probe housing, take care that there are no air bubbles on the tip of the fluoride probe in front of the LaF_3 crystal.
 - ▶ Tighten the threaded connection of the probe carefully with a spanner (size 17 mm).

Test the hydraulic installation of the probes:

- ▶ Set the flow at the stopcock to 20...60 l/h.
- ▶ Check that the threaded connection with the in-line probe housing is tight.
- ▶ If lots of air bubbles appear on the surface of the LaF_3 crystal, increase the flow by 10 l/h at a time until the problem is remedied.

5.3 Installation, electrical



WARNING

Installation must be carried out by an expert.

Do not connect the DULCOMETER® D1C measuring device to the mains until installation is complete.

For terminal connections in the DULCOMETER® D1C measuring device, see “DULCOMETER® D1C Operating Instructions Part 1”: Assembly and Installation of Wall and Panel Mounted Devices”, chap. 4.3.1 and 4.3.2 “Installation, electrical”.

5.3.1 Measured value transmission

The DULCOMETER® D1C converts the range between 0.00...2.00 ppm fluoride into a 4...20 mA signal. (Output 1 (terminal 9(+) and 10(-) of terminal strip X2)). From there this signal can be sent to a control centre or a PLC. The PLC must also be programmed to monitor current less than 3.8 mA. $I < 3.8$ mA represents a malfunction and must trigger an alarm signal which if necessary switches off the metering process.



IMPORTANT

Even when the analogue output of the DULCOMETER® D1C is connected to a PLC the alarm relay for monitoring a general alarm of the DULCOMETER® D1C must be connected to the PLC and evaluated.

5.3.2 Limit value monitoring

- via alarm relay in DULCOMETER® D1C measuring device

If fluoride values exceed preset limits, the alarm relay also transmits this information to the control room and overdosing is avoided (only when “checkout time limits” is set to > 0 s at the same time. (See “Adjusting DULCOMETER® D1C meter and PLC”).

It is recommended that the fluoride metering pump is not directly switched off with the alarm relay output but that a relay with several contacts is connected in between. This makes it possible to switch off the fluoride-metering pump directly, independently of the PLC, while at the same time activating a siren and/or warning light.

The alarm relay is connected to the PLC via terminals 1 and 3 of terminal strip XR3.

- via PLC (via limit relay)

If the PLC has no mA input, the limit relay can carry out the monitoring function described above. In this case relay 1 is set up as a limit relay. The limit relay is connected to the PLC via terminals 1 and 2 of terminal strip XR1. The alarm relay is connected to the PLC via terminals 1 and 3 of terminal strip XR3.



IMPORTANT

Even where limit values are transmitted via a PLC (if present) the alarm relay for monitoring a general alarm from the DULCOMETER® D1C must be attached to the PLC and evaluated.

- via PLC (via standard signal output 1)



IMPORTANT

Even where limit values are transmitted via a PLC (if present) the alarm relay for monitoring a general alarm from the DULCOMETER® D1C must be attached to the PLC and evaluated.

The connection of the standard signal output 1 to the PLC is described in the Measured value transmission section.

5.3.3 Flow monitoring



IMPORTANT

The flow of the sample water must be monitored since insufficient flow will produce fluctuating or false measured values.

The monitor is set up as a maximum limit contact, i.e. the contact is closed when the flow is normal. If the flow falls below a pre-set minimum value it opens and “pause” appears in the display. With appropriate circuitry the alarm relay can transmit this information as an alarm (audio/optical) to the control room. The handling also guarantees recognition of a break in the maximum limit contact cable.

- Flow alarm output via the alarm relay

In general a relay with several contacts should be connected to the alarm relay (terminals 3 and 1 of terminal strip XR3). This will enable an audio/optical alarm to be triggered and switch off the fluoride-metering pump.

- Flow alarm output via standard signal output 1.

Here the standard signal transmitted from the DULCOMETER® D1C measuring device to standard signal output 1 is looped through the alarm relay. The fall of the flow below the minimum value is indicated by a drop in the signal to 0 mA.

The electrical connection is made when one wire of the two wire lead for the transmission of the 4...20 mA standard signal is connected to terminal 2 (-) of the mA output 1 on terminal strip X2 of the DULCOMETER® D1C and the second wire (+) is connected to terminal 2 of terminal strip XR3 (alarm relay). Terminal 1(+) of the mA output on terminal strip X2 is connected to terminal 3 of terminal strip XR3 with a short single wire cable. When the maximum limit contact is closed (during normal flow), terminals 3 and 2 are connected and transmit the current signal of the standard signal output 1. When the flow falls below the minimum flow limit the alarm relay opens and breaks off the signal (0 mA). In this case the analogue current signal (4...20 mA) must be monitored in the PLC to check that it does not fall below 3.8 mA. If this happens, the PLC must switch off the proportional fluoride metering pump and trigger an audio/optical alarm.

Fig. 5

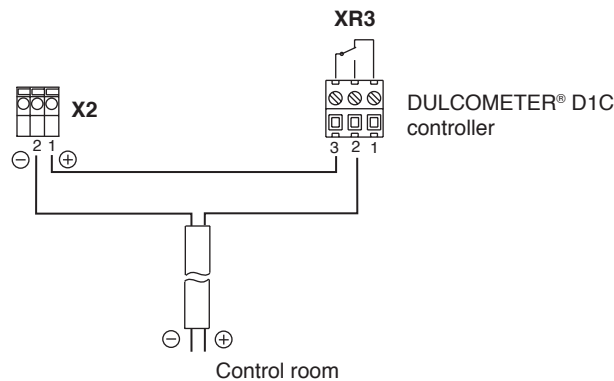

5.3.4 Probes

- ▶ Disconnect the measuring device from the power supply.

Pt 100 Depending on the identity code the DULCOMETER® D1C measuring device is equipped with a direct input for the Pt 100 via terminal or standard signal input (via transducer 4...20 mA):

- direct input via terminal (Identity code "Correction variable": 2): This is identified by a grey signal cable with an orange SN6 plug.
 - ▶ Screw the orange SN6 plug directly onto the Pt 100.
- Standard signal input (identity code "Correction variable" 3): Identified by a second 4...20 mA measuring transmitter (the Pt 100 V1) with a red seal and labelled "Pt 100 " connected to the DULCOMETER® D1C measuring device.
 - ▶ Screw the transmitter by hand onto the Pt 100.

Reference electrode ▶ Screw the single wire signal cable with the SN6 plug (black) of the FP V1 transmitter to the reference electrode REFP SE.

Fluoride probe ▶ Screw the 4...20 mA FP V1 resp. FP 100 V1 measuring transmitter (yellow seal and labelled "F-") by hand onto the fluoride probe until the threaded connection is firm.



IMPORTANT

It is essential that you contact your ProMinent subsidiary before using an potential equalizer rod for measuring.

5.3.5 DULCOMETER® D1C meter supply voltage



IMPORTANT

Check the correct supply voltage for the DULCOMETER® D1C measuring device on the nameplate.

- ▶ Connect the voltage supply to terminal L (phase) and terminal N (neutral) of terminal strip XP.
- ▶ Supply socket (min. IP 54) for operation of magnetic stirrer.

6 DULCOMETER® D1C meter and PLC settings

Operating keys of the D1C measuring device, see “Operating Instructions DULCOMETER® D1C Part 2”: Adjustment and operation, Measured Variable Fluoride”.

The next section describes the menu settings in the DULCOMETER® D1C for measurement transmission and limit value and flow monitoring, along with relevant examples.

The measurement device DULCOMETER® D1C must be switched over in the full operating menu. To do this, go to the “general setting information” menu and confirm four times. In this “operating menu” use the change key to go to the bottom low, select “complete” and confirm.

Fig. 6

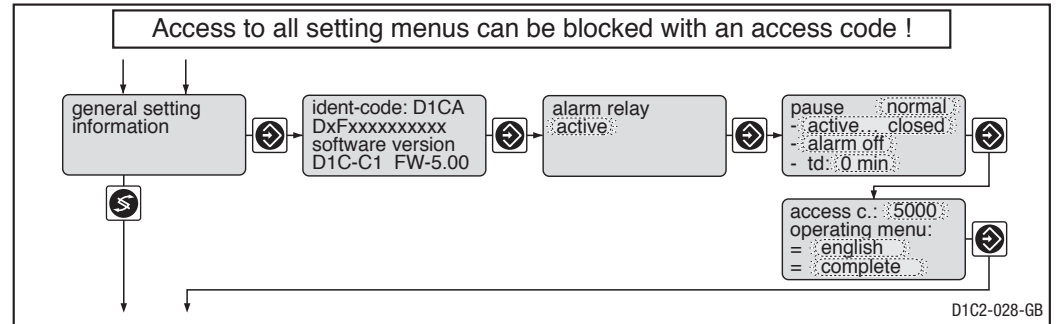

6.1 Measured value transmission

Fig. 7

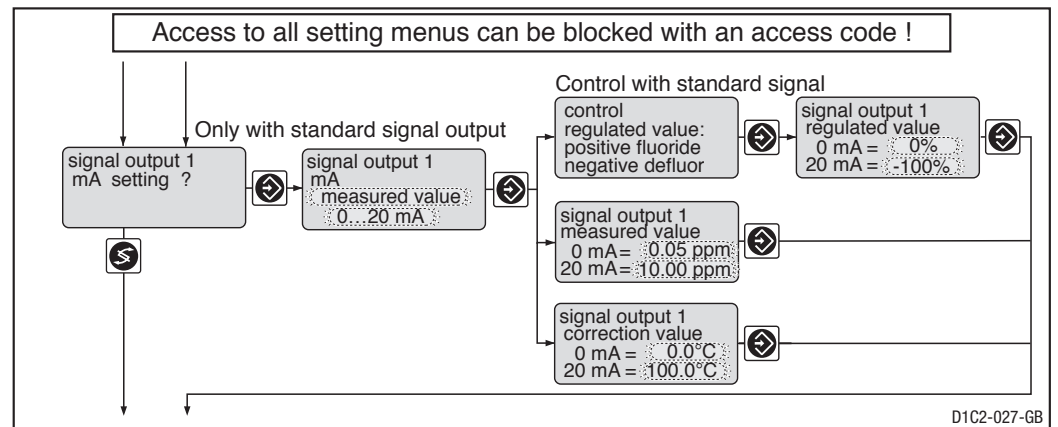

The standard signal output 1 must be set accordingly:

- ▶ In the complete operating menu, select the “signal output 1 mA setting?” option and confirm.
- ▶ In the following menu select “measured value” (Default) and change to the next option.
- ▶ Select “4...20 mA” and confirm.
- ▶ In the next menu, allocate the required fluoride ppm values to the 4 mA and 20 mA signals (e.g. 4 mA = 0.00 ppm and 20 mA = 2.00 ppm (default can be adjusted to maximum 10 ppm)).
- ▶ The PLC must also be programmed to monitor current less than 3.8 mA. $I < 3.8$ mA represents a malfunction and must trigger an alarm signal which if necessary switches off the fluoride metering process.



IMPORTANT

Even when the analogue output of the DULCOMETER® D1C is connected to a PLC (if present) the alarm relay for monitoring a general alarm of the DULCOMETER® D1C must be connected to the PLC and evaluated.

6.2 Limit value monitoring

- via alarm relay in DULCOMETER® D1C measuring device

Fig. 8

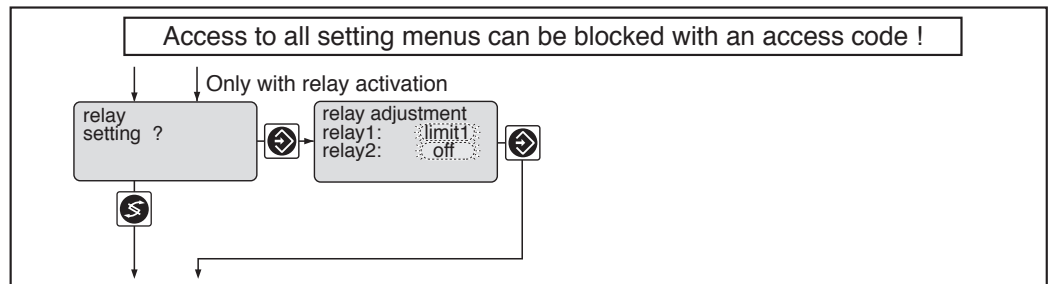

In order to notify the control room that the fluoride concentration has exceeded limits and to prevent overdosing the operator needs to specify certain settings on the DULCOMETER® D1C.

- ▶ In the “limits setting?” menu, set “limit 1” to “upper”, change to the next option and set to e.g. 1.00 ppm.



IMPORTANT

Observe national regulations concerning limit values!

- ▶ “Limit 2” is not required and can be deactivated by switching “limit 2” to “off”.
- ▶ Recommended “hyst.”, i.e. the downward hysteresis of the measured value after a value has exceeded a limit without resetting the relay is “0.05 ppm” (default). I.e. the measured value must fall below 0.95 ppm in the above example in order for the relay to reset.
- ▶ For an exceeded limit value to be indicated as alarm via the alarm relay both on the measuring device and in the control room, a time value (e.g. 10s) has to be entered in the menu option “limit faults” via “Δt on”. This setting ensures that both the limit value relay and the alarm relay are activated after a limit value has been exceeded. The alarm relay is then triggered if the limit value is exceeded for longer than 10 s. A limit value infringement is thereby also output as an alarm. It is recommended that the fluoride metering pump is not directly switched off with the alarm relay output but that a relay with several contacts is connected in between. This makes it possible to switch off the fluoride-metering pump directly, independently of the PLC, while at the same time activating a siren and/or warning light.

- via PLC (via standard signal output 1)

Fig. 9

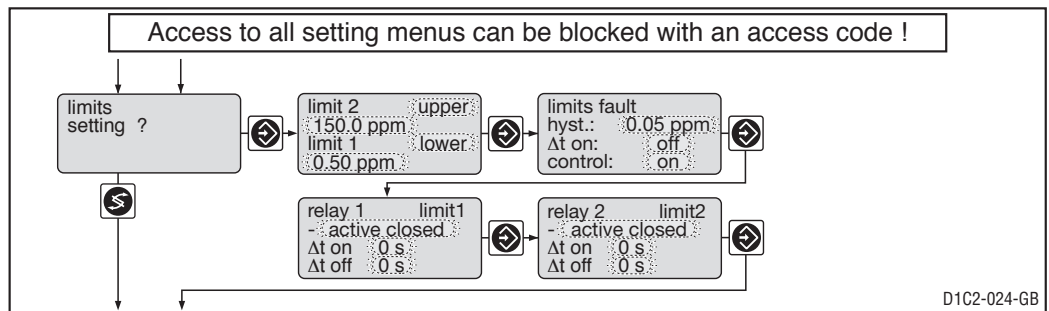

D1C2-024-GB

The programming of the parameters for limit value monitoring, the switching off of the fluoride metering pump and the triggering of an alarm in the event of limit values being exceeded is carried out via the PLC. The PLC must also monitor the standard signal output signal < 3.8 mA which indicates a break in the signal cable.

The connection of the standard signal output 1 to the PLC is described in the chapter 6.1 Measured value transmission.

- via PLC (via limit value relay)

Fig. 10

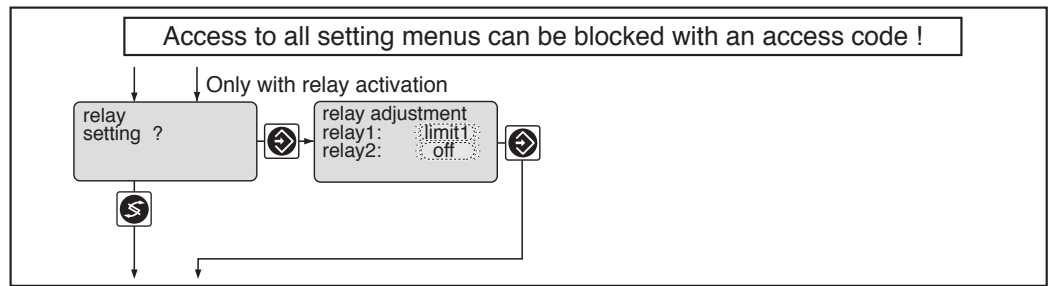

If the PLC has no mA input, the monitoring function described above can be carried out by the limit value relay. In this case relay 1 is set up as a limit value relay.

- ▶ To do this, go to the “relay setting?” menu and by confirming the “relay adjustment” option select “relay 1: limit 1” (default) and set and confirm “relay 2: off”.

If a specified upper limit value is exceeded, the alarm relay is triggered with a time delay of 1s.

Fig. 11

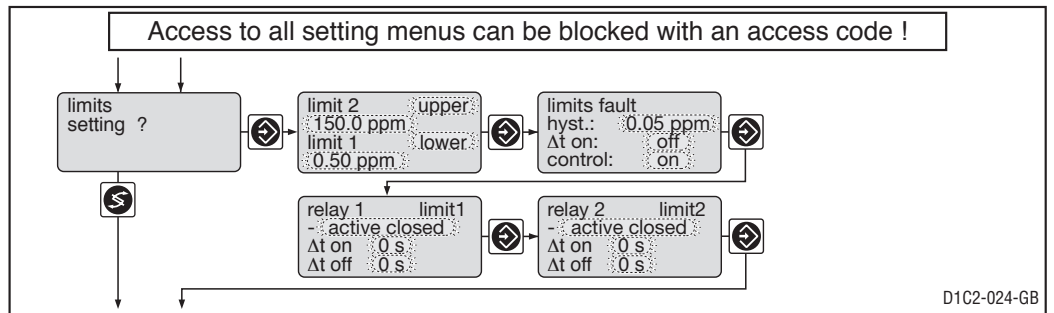

- ▶ In this case set the “limit 1” to “upper” in the “limits setting?” menu and in the next option select, e.g. 1.00 ppm.



IMPORTANT

Observe national regulations concerning limit values!

- ▶ “Limit 2” is not required and can be deactivated by switching “limit 2” to “off”.
- ▶ Recommended “hyst.”, i.e. the downward hysteresis of the measured value after a value has exceeded a limit without resetting the limit value relay is “0.05 ppm” (default). I.e. the measured value must drop below 0.95 ppm in the above example in order that the relay can reset.
- ▶ Enter the smallest time possible (i.e. 1s) via “Δt on” in the menu option „Limit value error”. (Do not set to “off”!)

If the fluoride concentration exceed the upper limits, the alarm relay is triggered e.g. with a 1 s time delay.

The alarm relay is connected to the PLC via terminals 1 and 3 of terminal strip XR3.



IMPORTANT

Even when measured values are transmitted or limit values are monitored via a PLC the alarm relay for monitoring a general alarm from the DULCOMETER® D1C must be transmitted to the PLC and evaluated.

The PLC should be programmed so that fluoride metering is switched off when the limit value or the alarm relay has been triggered. If the alarm relay is triggered this usually means that the measured value at the DULCOMETER® D1C is defective (e.g. no sample water flow, transducer cable break, controller system error etc.).

6.3 Flow monitoring



IMPORTANT

The flow of the sample water must be monitored since insufficient flow will produce fluctuating or incorrect measured values.

In self-contained DULCOMETER® D1C devices the flow monitor is designed as a N/O relay (default). The disadvantage of this is that it cannot monitor cable breaks. Therefore the flow meter has to have maximum value contact, e.g. this contact is closed during normal flow (pre-mounted DULCOMETER® D1C devices are set up in this way). If the flow drops below a pre-set minimum level (see overview table) the pause input is opened. “Pause” then appears in the display. When connected appropriately, the alarm relay can transmit this information as a general alarm (audio/optical) to the control room. The process also guarantees recognition of a break in the maximum limit value contact cable.

Menu setting “pause contact”	Float in flow monitor	Maximum value contact	Alarm relay	Display
“active open”	top	closed	off	
	bottom	open	on	“pause E”

The minimum flow limit is set by shifting the limit value contact on the flow meter up or down.

The alarm relay must be activated **for all flow monitoring variants**.

Fig. 12

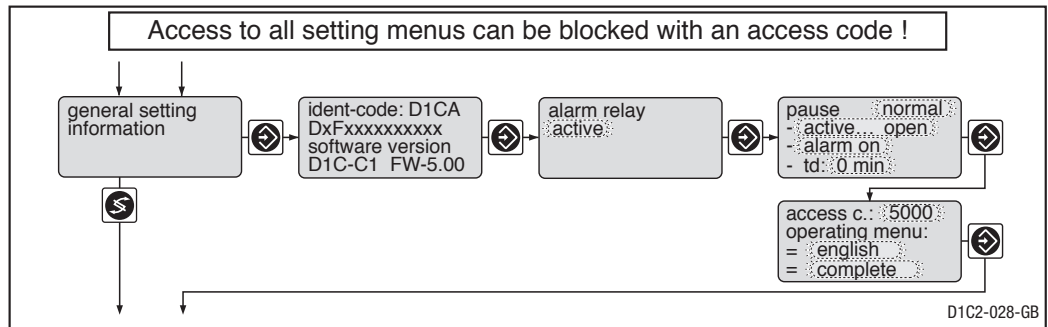

- ▶ For this, go to “general setting information” and confirm twice.
- ▶ Set the “alarm relay” to “active” and confirm.
- ▶ Acknowledge this and in the following menu point “Pause” set to “normal” (default) and “active open” and “alarm on”.
- ▶ Confirm twice with Enter Button to return to the permanent display.

- Flow alarm output via the alarm relay

The appropriate settings for the alarm relay are given in the previous section.

In general a relay with several contacts should be connected to the alarm relay (terminals 3 and 1 of terminal strip XR3). This will enable an audio/optical alarm to be triggered and switch off the fluoride-metering pump.

- Flow alarm output via standard signal output 1.

Here the standard signal transmitted from the DULCOMETER® D1C measuring device to standard signal output 1 is looped through the alarm relay. If the flow drops below the minimum limit, the signal output current drops to 0 mA.

The appropriate settings for the alarm relay have been made two sections above.

When the flow drops below the minimum limit the alarm relay opens and breaks off the signal (0 mA). Therefore the analogue output signal (4...20 mA) must be monitored in the PLC to determine whether it drops below 3.8 mA. If this happens, the PLC must switch off the proportional fluoride metering pump and trigger an audio/optical alarm.

7 Commissioning

7.1 Setting up limit value contact

The minimum flow value is set by shifting the limit value contact on the rotameter up or down (limit value contact can be fixed in place with the screw on the side). Position the limit value contact somewhat below the float. The alarm relay should not be triggered at this point.

To test the flow, reduce the flow rate with the stopcock until the alarm relay is triggered. Then restore the desired flow, acknowledge the alarm and remedy any consequential effects on the overall system (e.g. restart fluoride pump if necessary).

7.2 Function test



IMPORTANT

When the electrical installation and software settings have been completed, they should be tested to ensure they are functioning correctly.

NOTE

At the start of the test there should be no error messages displayed on the DULCOMETER® D1C and the limit relay should not have been triggered.

Carry out a function test as follows to check whether the DULCOMETER® D1C settings and the subsequent processing of the signals via the alarm relay and/or PLC are correct:

1. Testing flow monitoring function

Stop the flow at the stopcock. This should result in the following responses:

- “Pause E” appears in the DULCOMETER® D1C display
- Metering must be stopped by the downstream facilities and all installed audio and optical messages must be activated.

Then test the system to ensure that the system responds correctly when an error has been remedied. Reopen the stop valve and set to the original value. This should result in the following responses:

- “Pause E” disappears from the DULCOMETER® D1C display. The flow depending on the PLC programming and/or alarm relay or limit relay, fluoride metering starts automatically and/or is restarted via manual resetting of the error message.

2. Testing limit value monitoring function

To test limit value infringements, unscrew the 4...20 mA FP V1 resp. FP 100 V1 measuring transducer from the fluoride probe and use a wire jumper to short circuit the SN6 plug at the bottom end of the transducer. This should result in the following responses:

- The DULCOMETER® D1C measured variable display should jump to ↑10 ppm and the message “fluor. input E” should appear.
- The fluoride metering pump must be stopped by PLC, alarm relay or limit relay and all audio and optical messages should be activated.

The system is then tested to ensure that the overall system responds correctly when a limit value infringement has been remedied. For this, remove the short circuit jumper from the SN6 plug to the measuring transducer and screw this by hand back onto the fluoride probe. This should result in the following responses:

- The DULCOMETER® D1C measured variable display should jump from 10 ppm back to the original value and the message “fluor. input E” should disappear.
- Depending on the PLC programming and/or alarm relay or limit relay, the fluoride metering pump starts automatically and/or is started via manual resetting of the error message.

7.3 Running in fluoride probe

Allow the fluoride probe to run in for approx. 1 h in a constant flow of potable water with approx. 0.5 ppm fluoride concentration (the potential is considered to be stable if the change is less than 0.05 mV/min).

If the sample water does not contain fluoride in the range of approx. 0.5 ppm: close the stopcock and remove the DLG cup. Put a 0.5 ppm solution and the stirring rod into the cup and screw back together. Switch on the magnetic stirrer and allow the fluoride probe to run in.

Then calibrate the fluoride probe.

NOTE

The stirring rod should be left in the DLG.

7.4 Calibrating fluoride probe

The operator must choose between one-point calibration (y-axis section E_s : parallel shift of the calibration lines along the potential axis) and a two-point calibration (y-axis section E_s and fluoride probe slope S). The DULCOMETER® D1C requires E_s and S in order to calculate a fluoride concentration from a measured potential.

One-point calibration is carried out by determining the y-axis section E_s in a standard solution of e.g. 1 ppm fluoride.

Two-point calibration needs two calibration solutions which ideally differ by more than 1 ppm (minimum value 0.5 ppm), from which the y axis section E_s and the fluoride probe slope S can be determined.

Various fluoride calibration options are described next. They form a supplement to the Operating Instructions DULCOMETER® D1C Part 2, which describes calibration with the DULCOMETER® D1C only. In order to allow calibration values to be entered manually, calibration can also be carried out using a pH/mV meter (display accuracy at least 0.1 mV).

7.4.1 Calibration with photometer

One-point calibration in the restricted operating menu:

Take a water sample using the sampling tap and measure in accordance with the Photometer manufacturer's instructions.

Directly after taking the sample, go to the "calibration F" menu in the DULCOMETER® D1C measuring device and press the "Enter" key. The flashing temperature display is the actual temperature measured by the Pt 100 which is used for calibration. During the Photometer measurement the fluoride probe is permanently in the water. The probe does not need any run-in time. The calibration can be started immediately with the Enter key.

When the next menu option appears, the last calibrated fluoride concentration will be suggested in the "buffer" menu (limits 0.25 – 1.25 ppm); enter the fluoride content as determined with the photometer and confirm 2x. This concludes the calibration.

7.4.2 Calibration with DULCOMETER® D1C or pH/mV meter



IMPORTANT

- **The standard fluoride solutions should be kept in plastic containers after use. The calibration should take place in plastic containers (e.g. the measuring cup of the DLG IV in-line probe housing). Don't use glass containers as fluoride is adsorbed on glass and this can result in errors particularly in low concentrations.**
- **Do not use TISAB in the calibration. TISAB will lead to wrong calibration values.**
- **A magnetic stirrer is to be used for the calibrations (included in delivery). A moderate, constant stirring speed is to be maintained for all calibrations.**

NOTE

The DULCOMETER® D1C measuring device works with the absolute slope value. For this reason the algebraic sign is not taken into account below.

In addition to the equipment supplied you will need the following:

- A basic solution (see below)
- A 1000 ppm standard fluoride solution
- A 250 ml graduated cylinder or 250 ml volumetric flask
- Two piston pipettes with maximum volumes of 200 µl and 1.000 µl.

When calibrating with a pH/mV meter you also need an adapter cable to connect the SN6 fluoride probe and reference electrode connectors to the corresponding device.

Basic solution Calibration is ideally carried out in a basic solution with a conductivity of 1,000-1,500 µS/cm due to the more rapid potential adjustment (see chapter 4.2.2 Features of the probe). This has no effect on the slope.

Prepare the basic solution as follows:

Dissolve a suitable salt in de-ionized water, e.g. 1 g/l Na₂SO₄.



IMPORTANT

Neither water nor salt must contain fluoride in any form whatsoever.

*Calibration with
DULCOMETER® D1C*

The DULCOMETER® D1C fluoride controller offers two calibration options:

- One-point calibration in the restricted operating menu:
- Two-point calibration in the complete operating menu.



IMPORTANT

Immerse the fluoride probe, the reference electrode and the temperature gauge into the same standard solution.

- One-point calibration in the restricted operating menu

Fig. 13

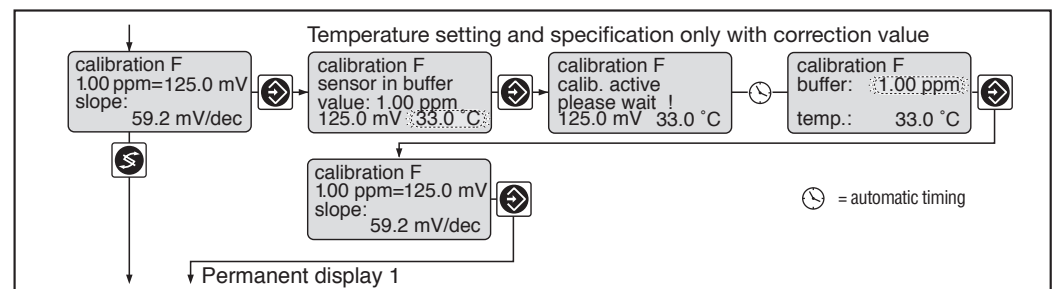

Use a pipette to add e.g. 250 µl of a 1,000 ppm standard fluoride into 250 mL of the Na₂SO₄ base solution. This corresponds to a solution of 1 ppm.

Stop the flow at the stopcock, unscrew the DLG cup and empty. Shake out the remaining water. Fill with the prepared 1-ppm solution and screw the cup back on. Place the magnetic stirrer under the cup and set to a medium stirring speed.

Once the mV signal which is visible in the changing display is stable (fluctuation < 0.05 mV/min), go to “calibration F” in the settings menu and press the “enter” key. The flashing temperature display in the following menu is the actual temperature measured by the Pt 100 during calibration. Press “enter” to start calibration.

When the next menu appears, the last calibrated fluoride concentration will be suggested in the “buffer” menu (limits 0.25 – 1.25 ppm); enter the fluoride content of the calibration solution and confirm 2x. This concludes the calibration.

Unscrew the cup, empty and screw back on. Open up the stopcock again to release the flow.

b) Two-point calibration in the full operating menu

Fig. 14

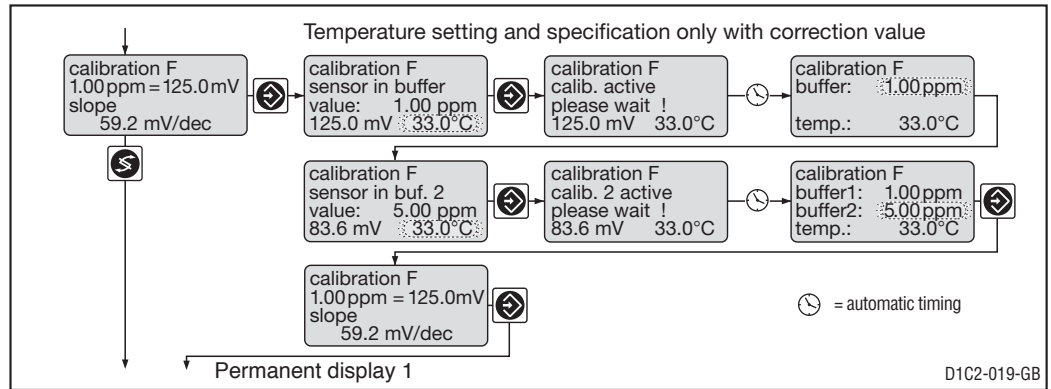

Use a pipette to add e.g. 125 µl of a 1,000 ppm standard fluoride into 250 ml of the Na₂SO₄ base solution. This corresponds to a solution of 0.5 ppm.

Stop the flow at the stopcock, unscrew the DLG cup and empty. Shake out the remaining water. Fill with the prepared 0.5 ppm solution and screw the cup back on. Place the magnetic stirrer under the cup and set to a medium stirring speed.

Once the mV signal which is visible in the changing display is stable (fluctuation < 0.05 mV/min), go to “calibration F” in the settings menu and press the “Enter” key. The flashing temperature display in the following menu is the actual temperature measured by the Pt 100 during calibration. Press “Enter” to start calibration for the first concentration value.

When the next menu option appears, the last calibrated fluoride concentration will be suggested in the “buffer” menu (limits 0.25 – 1.25 ppm); enter the fluoride content of calibration solution 1 and confirm 2x.

Unscrew the DLG cup once more (do not pour the solution, allow probe to drip) and add a further 375 µl of a 1,000 ppm standard fluoride with the pipette. This corresponds to a total concentration of 2 ppm. Reattach the cup and press “Enter” after the measurement signal has stabilised (fluctuation < 0.05 mV/min).

When the next menu appears, the last calibrated fluoride concentration will be suggested in the “buffer 2” menu (limits 1.75 -10.00 ppm); enter the fluoride content of calibration solution 2 and confirm 2x. This concludes the calibration.

Only then should you unscrew the cup and empty (leave stirring rod in the cup) and screw back on. Open up the stopcock again to release the flow.

Calibration with pH/mV meter



IMPORTANT

- **Observe pH/mV meter operating instructions!**
- **Immerse the fluoride probe, the reference electrode and the temperature gauge into the same solution.**

NOTE

The two standard solutions have been selected here so that the potential difference E1 – E2 corresponds precisely to the fluoride probe slope S. (This is always the case when the fluoride concentrations of the two standard solutions differ by a factor of 10).

Two-point calibration (entering values in complete operating menu):

Unscrew the transducer and the SN6 cable from the fluoride probe and the reference electrode. Connect the two probes and the pH/mV meter with the adapter cables. Leave the Pt 100 connected to the DULCOMETER® D1C.

Use a pipette to add e.g. 125 µl of a 1,000 ppm standard fluoride into 250 ml of the Na₂SO₄ basic solution. This corresponds to a solution of 0.5 ppm.

Stop the flow at the stopcock, unscrew the DLG cup and empty. Shake out the remaining water. Fill with the prepared 0.5 ppm solution and screw the cup back on. Place the magnetic stirrers under the cup and set to a medium stirring speed.

When the mV signal displayed by the pH/mV meter is stable (fluctuation < 0.05 mV/min), read off value (E1) and make a note of it.

Unscrew the DLG cup once more (do not shake the solution, allow probe to drip) and add a further 1,125 µl of a 1,000 ppm standard fluoride with the pipette. This corresponds to a total concentration of 5 ppm. Reattach the cup and after the measurement signal has stabilised (fluctuation < 0.05 mV/min, read off the value (E₂) and make a note of it.

Deduct 62 mV each from the values E₁ and E₂:

$$E_1 \text{ (D1C)} = E_1 - 62 \text{ mV}$$

$$E_2 \text{ (D2C)} = E_2 - 62 \text{ mV}$$

NOTE

The potential difference in these two calibration concentrations corresponds precisely to the probe slope S:

$$S = E1 \text{ (D1C)} - E2 \text{ (D1C)}$$

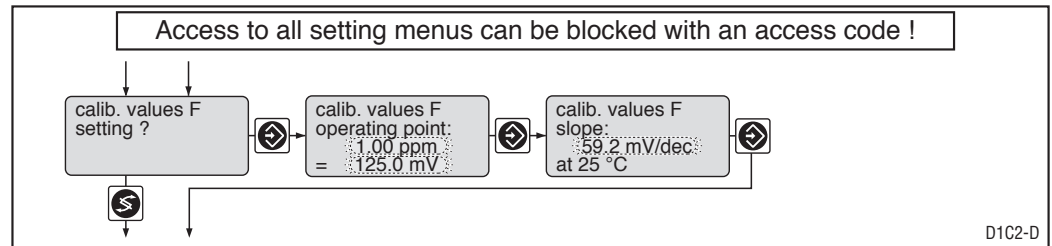

In the measuring device, select the “calib. values F setting?” menu and confirm. In the “calib. value” “operating point” menu enter the concentration of the first calibration solution (in this example 0.5 ppm) and the corresponding potential E₁ (D1C) and confirm. In the following menu option - “slope” - enter the potential difference S = E₁ (D1C)-E₂ (D1C) and confirm. This concludes the calibration.

Then unscrew the adapter cable from the probes and reconnect the transducer to the probe and the reference electrode. Unscrew the cup, empty and screw back on. Open up the stopcock again to release the flow.

DULCOMETER® D1C fault messages

Fault message	Condition	Effect
Fluoride concentration difference too small	Fluoride concentration < 0.5 ppm F ⁻	During calibration: calibrate fluoride concentration 2 again!
Standard value low	< 100 mV	Back to permanent display WARNING, old standard value and slope retained " " " " "
Standard value high	> 150 mV	
Slope low	< 40 mV/dec	
Slope high	> 65 mV/dec	
Measured mV value unstable		
Measured °C value unstable		

8 Maintenance

Carry out regular visual inspections of the fluoride measuring system, particularly the fluoride probe, the in-line probe housing and the flow meter.

- ▶ Look for:
 - air bubbles in the sample water
 - air bubbles in front of the LaF_3 crystal of the fluoride probe
 - leaks
 - correct flow value

- ▶ Check that the limit value sensor is seated firmly on the flow meter.

- ▶ Check that the float can move freely inside the flow meter.
You need to alter the flow: the float should move. If necessary, clean the flow meter and then test its function again (change flow).

Cleaning the FLEP fluoride probe



IMPORTANT

The fluoride probe must be rinsed out thoroughly after being cleaned.

The fluoride probe can be cleaned if necessary. Dirt should be removed as carefully as possible with a soft, damp, lint-free paper towel.

In exceptional cases the LaF_3 crystal can be polished to remove strongly adhering dirt on a soft lint-free paper towel with a polishing paste designed for acrylic glass (order number 559810). Hold the fluoride probe upright to ensure that material is removed evenly. Rinse off the remaining polishing paste with lukewarm water. Then run in the fluoride probe in potable water with approx. 1 ppm fluoride concentration at constant flow (the potential is considered to be stable if the change is less than 0.05 mV/min) and recalibrate.

Cleaning the REFP reference electrode

The ceramic diaphragm attached below can be cleaned either with non-abrasive domestic cleaning agents or by soaking for 1 - 5 minutes in dilute saltwater (0.1 – 3 %). If necessary you can clean it with your fingernail or a fine file (see also “Recommendations for handling and servicing pH and redox (ORP) combination probes”).

9 Troubleshooting

Error: Measurement signal unstable

Cause

- Measuring cable with DN6 connector not correctly screwed onto transducer, reference electrode or Pt 100
- Reference electrode defective
- Moisture inside plug
- Earthing problems/earth loop
- Air bubbles in front of the fluoride probe

- LaF₃ crystal dirty

Remedy:

- Screw up to the stop,
Do not cross-thread

- Replace reference electrode
- Dry the plug
- Check
- Depressurise in-line probe housing
Loosen fluoride probe and turn
Under certain circumstances increase flow
- Clean (see Recommendations of handling and servicing fluoride sensors)

Error: Display unchanged in all solutions

Cause

- Fluoride probe not connected
- Short circuit in fluoride probe
- Cable defective
- Measuring transducer defective

Remedy:

- Connect fluoride probe
- Replace fluoride probe
- Replace cable
- Replace measuring transducer

Error: Slope too low and/or too high

Cause

- LaF₃ crystal dirty

- Incorrect standard solution used
- pH limits exceeded
- Presence of complex-forming cations
- Fluoride probe leaking

Remedy:

- Clean (see Recommendations of handling and servicing fluoride sensors)
- Prepare new standard solution
see chapter 4.2
- see chapter 4.2
- Replace fluoride probe

Error: Drifting fluoride probe signal

Cause

- Reference electrode defective/spent
- Fluoride probe leaking

Remedy:

- Replace reference electrode
- Replace fluoride probe

10 Decommissioning

Fluoride measuring station

- ▶ Disconnect the fluoride measuring station from the power supply.
- ▶ Disconnect the fluoride measuring station's hydraulic connections
- ▶ Detach the fluoride probe and the reference electrode and place in storage (see below).
- ▶ Allow all sample water to drain out of the fluoride measuring station.
- ▶ Plug all openings.

FLEP fluoride probe



IMPORTANT

The fluoride probe must not be stored in distilled/de-ionized water.

Storage The fluoride probe must be rinsed after use with de-ionized water and dried with a soft lint-free paper towel. Take care to dab LaF_3 crystal gently. The fluoride probe can be stored in the short term in a fluoride solution (concentration ≥ 1 ppm F⁻; 5 < pH value < 9). The fluoride probe must not be stored in distilled/de-ionised water. For longer periods (> 1 week) store the fluoride probe dry in the storage container.

Service life The fluoride probe is subject to natural wear and tear even when handled correctly. Depending on use, it has a service life of between one and two years. This period can be shorter under difficult conditions such as extreme pressure and temperature fluctuations and low conductivities.

REFP reference electrode

- ▶ Store in 3M KCl solution in the storage container.
- ▶ Screw the probe tightly into the storage container.

11 Spare parts and accessories

	Order. No.
• Flow meter 0-60 l/h	1002466
• Maximum limit contact	1017887
• DULCOMETER® D1Ca fluoride controller	230 V 50/60 Hz = identity code W0F12011G000x 115 V 50/60 Hz = identity code W1F12011G000x
• Transmitter DULCOTEST® 4-20 mA FP V1	1028280
• Fluoride probe DULCOTEST® FLEP 010 SE/FLEP 0100 SE	1028279
• Reference electrode DULCOTEST® REFP SE	1018458
• Temperature probe DULCOTEST® Pt 100 SE	305063
• Pt 100 signal cable	1003208
• 230 VAC magnetic stirrer Euro-plug or 115 VAC USA-plug	790915 790916
• Magnetic stirring rod	790917
• Insert d16 (adapter for adhesive bushing)	356572
• G3/4 union nut	356562
• Adapter set, simple	740585
• Connector set 8x5 PCE	817048
• Connector set 6x4 PCE	817060
• Connector set 12x9 USA PCE	740160
• Connector set 12x9 PCE	817049
• Connector set 12x6 PCE	791040
• PE hose	(on request)

Dimensioned drawing

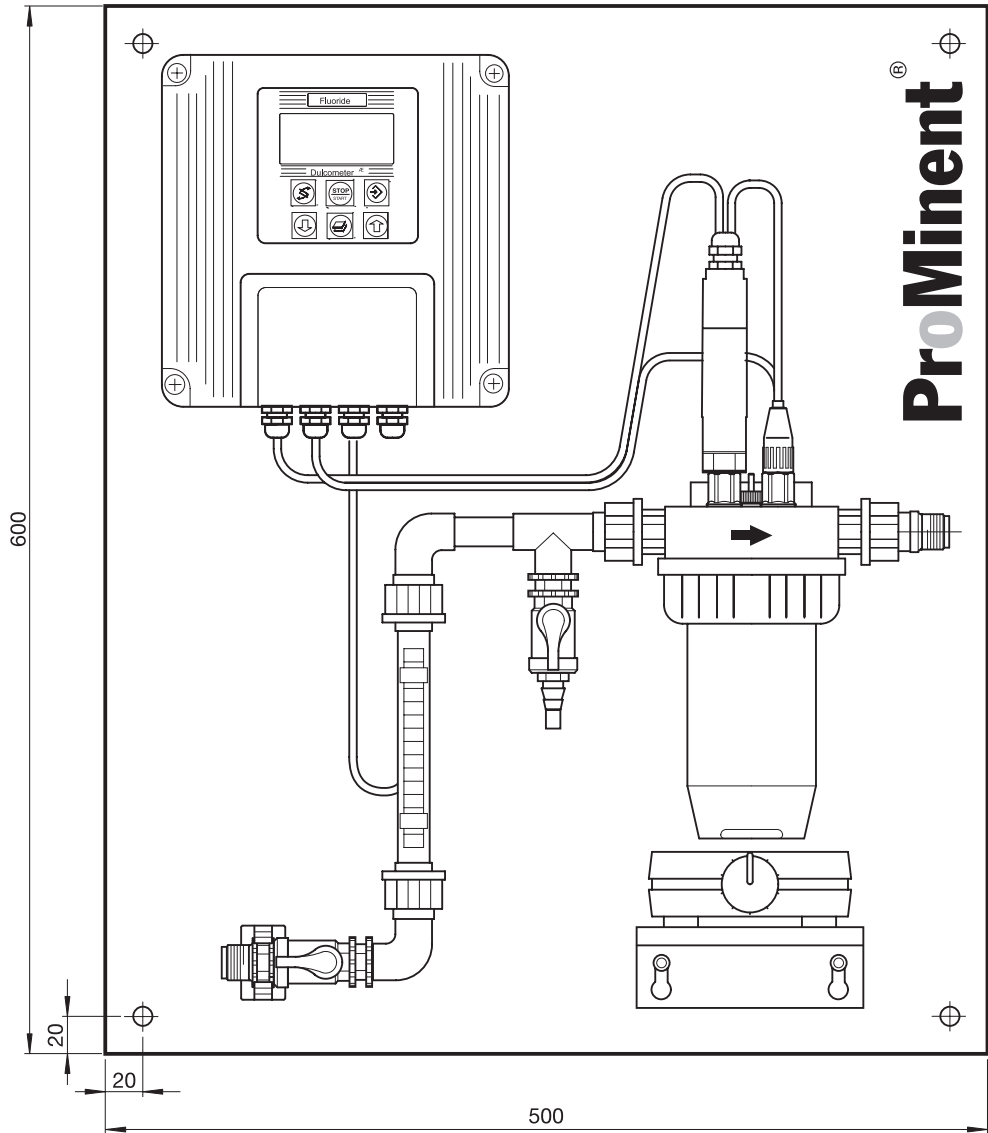

**Addresses and delivery
through manufacturer:**

ProMinent Dosiertechnik GmbH
Im Schuhmachergewann 5-11
D-69123 Heidelberg
Germany

Tel.: +49 6221 842-0
Fax: +49 6221 842-419

info@prominent.com
www.prominent.com